

alberta[®]
The first name in Italian sofas

alberta

via Toniolo 41, 31028 Vazzola (TV) - ITALY
www.alberta.it



BOOK 01/16



BLACK collection

Black è eleganza, fascino, forza.

Alberta sceglie un simbolo di raffinatezza e stile indiscusso per rappresentare la forza della sua nuova collezione. Linee geometriche e volumi accoglienti diventano un segno distintivo dell'azienda, sempre pronta a rinnovarsi per interpretare al meglio lo stile dell'abitazione contemporanea. Tessuti, finiture, colori sono selezionati ed accostati con cura e sapienza sartoriale, per creare prodotti unici ed esclusivi, capaci di "disegnare" lo spazio in cui sono inseriti con personalità ed un pizzico di ironia. L'intera collezione è stata disegnata da Alessandro Castello e Maria Antonietta Lagravinese.



Black is elegance, fascination, strength.

Alberta chooses a symbol of undisputed sophistication and style to express the strength of the new collection. The geometric lines and enveloping shapes become a trademark for the company, always ready to innovate to better express modern living styles. Fabrics, finishes, colours are all carefully and expertly selected and matched to create unique, exclusive products that "design" the interiors with all their personality and a touch of irony. The collection is designed by Alessandro Castello and Maria Antonietta Lagravinese.



Black c'est l'élégance, le charme, la force.

Alberta choisit un symbole de raffinement et de style incontesté pour représenter la force de sa nouvelle collection. Les lignes géométriques et les volumes accueillants deviennent un signe distinctif de l'entreprise, toujours prête à se renouveler pour interpréter au mieux le style de l'habitat contemporain. Les tissus, les finitions et les couleurs sont sélectionnés et associés avec soin et un savoir-faire artisanal, pour créer des produits uniques et exclusifs, en mesure de « dessiner » l'espace dans lequel ils sont intégrés avec personnalité et une pincée d'ironie. La collection a été créée par Alessandro Castello et Maria Antonietta Lagravinese.



Black ist Eleganz, Charme, Stärke.

Alberta entscheidet sich für ein Symbol der Eleganz und für unbestrittenen Stil, um die Stärke der neuen Kollektion zu zeigen. Die geometrischen Linien und behaglichen Formen werden so zu einem Erkennungszeichen der Firma, die jederzeit bereit ist, neue Wege einzuschlagen und den Stil modernen Wohnens gekonnt zu interpretieren. Stoffe, Oberflächen und Farben werden mit großer Sorgfalt und Schneiderkunst ausgewählt und für einzigartige und exklusive Möbel kombiniert. Möbel, die in der Lage sind, den Raum, in dem sie stehen, mit Persönlichkeit und einem kleinen Augenzwinkern zu "designen". Die Kollektion wurde von Alessandro Castello und Maria Antonietta Lagravinese konzipiert.

alberta

INDICE • INDEX

DIVANI • SOFAS.....	9
POLTRONE • ARMCHAIRS.....	157
TAVOLINI • SMALL TABLES.....	197
RIEPILOGO • SUMMARY.....	261
AREA PROGETTO • PROJECT AREA.....	283
FINITURE • FINISHING.....	287
DATI TECNICI • TECHNICAL DATA.....	291

DIVANI • SOFAS



FLOYD.....10



DYLAN.....44



MORRISON.....110



YOKO 2.....147



FLOYD 120 DEEP.....34



BOWIE.....60



BRUCE.....130



YOKO 1.....152



CINDY.....76



RONNY.....90

POLTRONE • ARMCHAIRS



GOSSIP158



JAMMIN170



JAMMIN LARGE176



FENDER184

TAVOLINI • SMALL TABLES



JAGGER200



BABAR210



PHIL222



FRISCO234



HUGO250

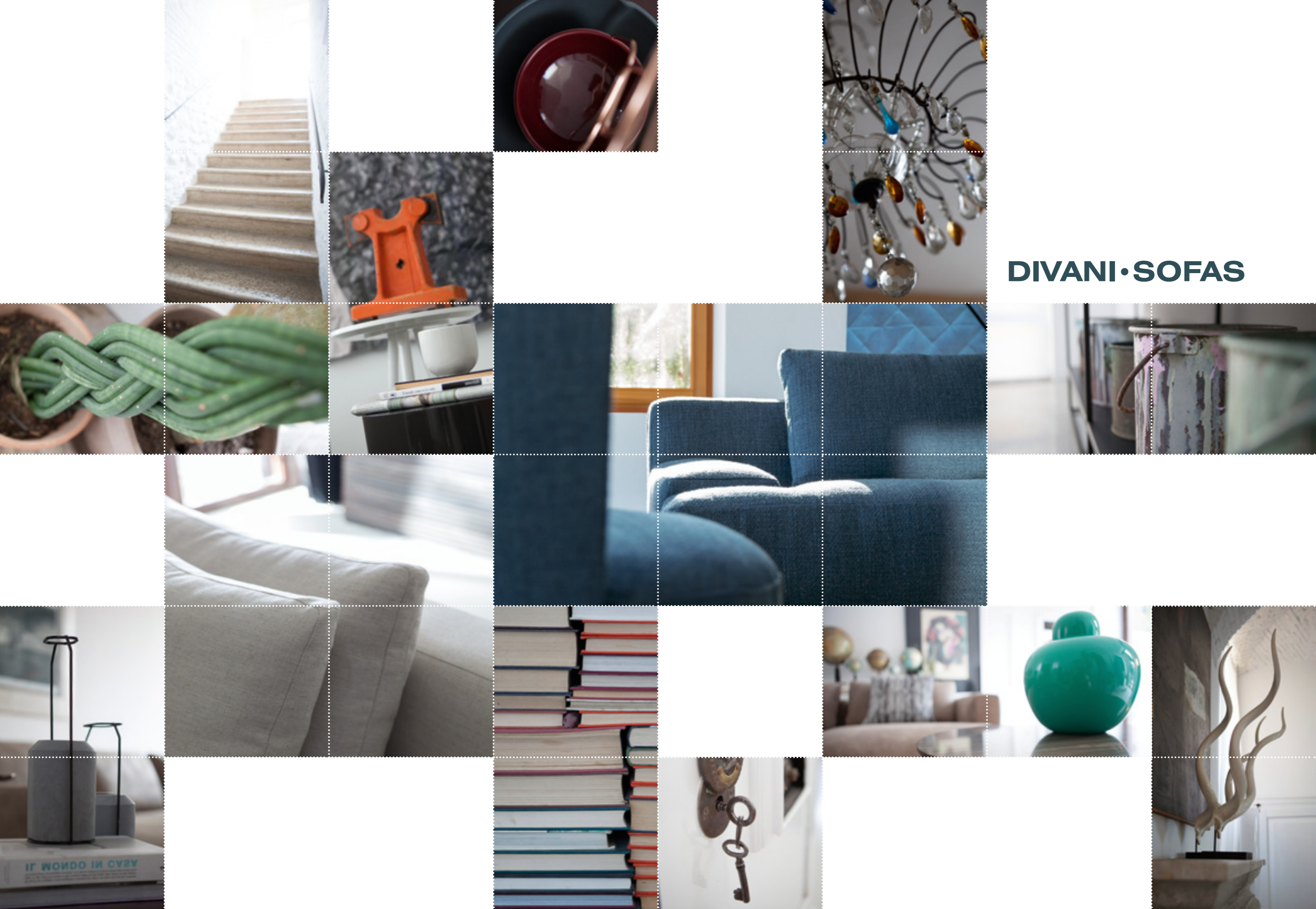

DIVANI • SOFAS

FLOYD



IT • Un basamento con linee geometriche, disegnate da cuciture sartoriali, caratterizza la serie di divani componibili Floyd. In alcune composizioni è previsto l'inserimento di un piano d'appoggio in marmo o laccato che si integra perfettamente con la base delle sedute, permettendo così di realizzare configurazioni insolite per soddisfare anche gli arredatori più esigenti. I piani complementari sono disponibili in diversi tipi di marmo e vari colori di laccato.

EN • A geometric base, designed by tailor stitching, characterizes the series of Floyd sectional sofas. In some compositions there is the possibility to insert a marble or lacquered top that matches perfectly the seat base, creating very unusual configurations for the more exacting interior decorators. Tops are available with different kinds of marble and different lacquered colors.

FR • Un piètement aux lignes géométriques dessinées par des coutures artisanales caractérise la série de canapés modulaires Floyd. Une collection qui prévoit la possibilité, dans ses différentes compositions, d'insérer un plateau en marbre ou laqué qui s'associe parfaitement avec la base des assises, donnant la possibilité aux décorateurs d'intérieur les plus exigeants de réaliser des configurations insolites. Les plateaux complémentaires sont disponibles dans différents types de marbre et différentes couleurs de laque.

D • Eine Basis it geometrischen Linien, die von den Ziernähten hervorgehoben werden, charakterisiert die Sitzlandschaft Floyd. Die Kollektion bietet verschiedene Gestaltungsmöglichkeiten, darunter das Einfügen einer Ablage aus Marmor oder Lackiert, die sich perfekt in die Basis der Sofaelemente integriert und mit der sich ungewöhnliche Kombinationen schaffen lassen, die auch anspruchsvollste Einrichter zufrieden stellen. Die Unterfläche sind in verschiedenen Marmorwahl und verschiedenen Lackierungsfarben lieferbar.

designed and dressed by
Alessandro Castello • Maria Antonietta Lagravinese















FLOYD composizione con tavolino/composition with small table/composition avec table/Komposition mit Couchtisch cm 302x100
FENDER poltrona girevole/swivel armchair/fauteuil tournant/Drehsessel
BABAR • HUGO • JAGGER 35 • JAGGER 75 tavolini/small tables/tables/Couchtischen







FLOYD composizione con tavolino/composition with small table/composition avec table/Komposition mit Couchtisch cm 364x382
GOSSIP poltrona/armchair/fauteuil/Sessel
JAGGER 75 • HUGO • FRISCO 75 tavolini/small tables/tables/Couchtischen











FLOYD composizione con tavolino/composition with small table/composition avec table/Komposition mit Couchtisch cm 177X145
GOSSIP poltrona/armchair/fauteuil/Sessel
PHIL tavolino/small table/table/Couchtisch





DYLAN



IT • Dylan è un sistema di sedute dalle linee morbide e allo stesso tempo rigorose. Realizzato con una seduta ampia, coniuga leggerezza e contemporaneità. Il basamento molto sottile e i piedini in metallo, disponibili in diverse finiture, ne disegnano la struttura dandogli un tocco glam. Dylan si adatta facilmente alle varie tipologie di abitazione moderna, rispondendo con originalità ed eleganza a tutte le esigenze del comfort.

EN • Dylan is a system of seats which are soft but linear at the same time. With its large seat, it fully expresses lightness and a contemporary style. The very thin base and metal feet, available with different finishings, give a glam touch to the frame. Dylan fits in easily with any kind of modern home, giving an original and elegant answer to everyday needs of comfort.

FR • Dylan est un système d'assises aux lignes douces et en même temps rigoureuses. Réalisé avec une large assise, il conjugue légèreté et modernité. Le piètement fin et les pieds en métal, disponibles dans différentes finitions, dessinent sa structure en lui donnant une touche de glamour. Dylan s'adapte facilement aux différents types d'habitation moderne, répondant avec originalité et élégance à toutes les exigences de confort.

D • Dylan ist eine Sitzlandschaft, die sich durch die weichen und gleichzeitig strengen Linien auszeichnet. Mit ihrer großzügigen Sitzfläche verbinden die Sofas Leichtigkeit mit modernem Wohnstil. Die zierliche Basis und die Metallfüße lieferbar in verschiedenen Feinbearbeitungen, charakterisieren das Gestell und verleihen diesen Sofas einen Hauch von Glamour. Dylan lässt sich einfach an die verschiedenen modernen Einrichtungsstile anpassen und wird mit Originalität und Eleganz allen Anforderungen an Wohnkomfort gerecht.

designed and dressed by
Alessandro Castello • Maria Antonietta Lagravinese

















BOWIE



IT • Forme lineari e comfort avvolgente contraddistinguono l'estetica del sistema di sedute Bowie, caratterizzato dalla leggerezza del disegno dei braccioli e dei piedini in metallo. Gli ampi cuscini di schienale conferiscono a questo modello una linea pulita associata ad un'accogliente intimità. Un divano disegnato per chi ama forme eleganti con particolare attenzione al comfort.

EN • Linear forms and enveloping comfort distinguish the esthetics of the Bowie seating system, characterized by the lightness of the design of the armrests and metal feet. The ample cushions of the backrest give this model a clean line associated with a comfortable intimacy. A sofa designed for those who love elegant forms, with particular attention to comfort.

FR • Des formes épurées au confort enveloppant définissent l'esthétique du système Bowie, caractérisé par la légèreté du design des accoudoirs et des pieds en métal. Les amples coussins du dossier font ressortir la pureté de la ligne tout en évoquant une atmosphère d'intimité chaleureuse. Un canapé conçu pour ceux qui estiment les formes élégantes et qui recherchent le confort.

D • Lineare Formen und einzigartiger Komfort bestimmen die Ästhetik des Sitzsystems Bowie, das sich durch die Leichtigkeit der Konstruktion der Arme und Beine aus Metall kennzeichnet. Die großen Rückenissen verleihen diesem Modell klare Linien, die mit einer kuscheligen Intimität verbunden sind. Dieses Sofa richtet sich an diejenigen, die elegante Formen mit einer besonderen Aufmerksamkeit auf Komfort lieben.

designed and dressed by
Alessandro Castello • Maria Antonietta Lagravinese





BOWIE divano/sofa/canapé/Sofa cm 260x106













CINDY



IT • Il sistema di sedute Cindy è stato creato con una particolare attenzione all'equilibrio dei volumi che lo compongono, con un disegno pulito e lineare grazie al basamento sottile e all'ampia seduta. Le svariate possibilità di composizione, rendono Cindy adatto alle diverse esigenze degli spazi abitativi moderni, conservando un comfort unico grazie agli accoglienti cuscini dello schienale.

EN • The Cindy seating system was created with special attention to the balance of the volumes that compose it, with a clean and linear design thanks to its thin base and ample seating space. The various compositional possibilities make Cindy ideal for the different needs of the modern living space, preserving a unique comfort, thanks to the hospitable cushions of the backrest.

FR • Cindy est un système qui privilège l'équilibre des volumes qui le composent, soutenu par les lignes épurées et essentielles d'une base mince et profonde. Tout en conservant un confort unique grâce aux coussins confortables des dossiers, Cindy se prête à d'innombrables solutions modulaires permettant de répondre aux différentes incitations des espaces modernes.

D • Beim Sitzsystem Cindy wurde ein besonderes Augenmerk auf das Gleichgewicht der verschiedenen Teile in Bezug auf die Abmessungen gelegt. Dank der grazilen Basis und den großen Sitzflächen besitzt das System klare Linien und ein lineares Design. Aufgrund den unzähligen Zusammensetzungsmöglichkeiten passt sich Cindy perfekt an die Bedürfnisse moderner Wohnräume an. Die gemütlichen Rückenpolster bieten einen unvergleichlichen Komfort.

designed and dressed by
Alessandro Castello • Maria Antonietta Lagravinese















RONNY



IT • Comfort estremo ed eleganza metropolitana contraddistinguono il divano componibile Ronny, in un equilibrio perfetto di linee e proporzioni. Gli eleganti piedini in metallo, disponibili in diverse finiture, donano lucentezza alle forme ricercate e leggerezza a tutta la struttura.

EN • Maximum comfort and urban elegance are the key features of Ronny sectional sofa, a clear example of perfect lines and proportions. The elegant metal feet, available with different finishings, give a touch of brightness to the sofa refined silhouette, making it particularly light and delicate.

FR • Le confort extrême et l'élégance métropolitaine caractérisent ce salon composable Ronny, dont lignes et proportions sont en parfait équilibre. Les pieds élégants en métal, disponibles en plusieurs finitions, accentuent la forme brillante et la légèreté de la structure.

D • Extremer Komfort und Eleganz prägen das Kombisofa Ronny, in einer perfekten Balance von Stil und Proportion. Die eleganten Metallfüßen, in verschiedenen Feinbearbeitungen geben Glanz den eleganten Formen und Leichtigkeit der gesamten Struktur.

designed and dressed by
Alessandro Castello • Maria Antonietta Lagravinese





















MORRISON



IT • Un divano dai volumi generosi che, con la sua assoluta comodità d'uso, si offre come accogliente riparo dove poter godere attimi di relax. Realizzato con un basamento molto sottile ed ampi cuscini di seduta, permette di creare svariate possibilità di composizione per soddisfare ogni esigenza del vivere quotidiano. I cuscini appoggiati allo schienale basso contribuiscono a dargli un comfort eccellente senza rinunciare però ad uno stile moderno ed essenziale.

EN • A generous and amazingly comfortable sofa, an embracing refuge for total relax. With a very thin base, large seat and a wide range of compositions to fit into any sort of living style. A series of additional back cushions make it even more comfortable, while remaining true to the modern and minimalist style.

FR • Un canapé aux volumes généreux qui, grâce à un confort d'utilisation absolu, devient un abri accueillant où profiter des moments de détente. Réalisé avec un piètement fin et de larges et confortables coussins d'assise, il permet différentes possibilités de composition pour satisfaire chaque exigence du quotidien. Une série de coussins apposés au dossier bas contribue à lui apporter un excellent confort sans pour autant renoncer à un style moderne et essentiel.

D • Ein großzügiges Sofa, das sich mit seinem absoluten Komfort als ideale Rückzugsmöglichkeit anbietet, wenn man ungestört entspannende Momente genießen möchte. Die Sitzlandschaft mit zierlicher Basis und bequemen, großen Sitzkissen bietet verschiedene Gestaltungsmöglichkeiten und wird so allen Anforderungen im Alltag gerecht. Eine Reihe Rückenkissen, die an der niedrigen Rückenlehne positioniert sind, garantieren für optimalen Sitzkomfort, ohne auf einen modernen und essentiellen Stil verzichten zu müssen.

designed and dressed by
Alessandro Castello • Maria Antonietta Lagravinese







MORRISON divano /sofa/canapé/Sofa cm 320x106
JAMMIN LARGE poltrona/armchair/fauteuil/Sessel
BABAR • JAGGER 35 • PHIL • FRISCO 50 tavolini/small tables/tables/Couchtischen















BRUCE



IT • Bruce è un sistema di sedute caratterizzato da linee morbide e confortevoli. L'originale disegno dei braccioli aumenta idealmente lo spazio di seduta, amplificando la percezione di comfort e relax. I volumi essenziali di questo modello si esprimono in un design contemporaneo ed accogliente che si inserisce perfettamente in ambienti moderni e funzionali.

EN • Bruce is a seating system characterized by soft and comfortable lines. The original design of the armrests seems to increase the seating space, amplifying the perception of comfort and relax. The essential volumes of this model express themselves in a contemporary and welcoming design that fits perfectly into modern and functional environments.

FR • Bruce est un système aux lignes adoucies et confortables. Le design original des accoudoirs est conçu pour optimiser l'espace assis et amplifier l'impression de confort et de délasserment. Les volumes accueillants de ce modèle s'expriment par un design contemporain et essentiel qui s'insère parfaitement dans un contexte moderne et fonctionnel.

D • Bruce ist ein Sitzsystem mit weichen und komfortablen Linien. Der originelle Entwurf der Armlehnen vergrößert auf ideale Weise den Sitzplatz, wodurch die Wahrnehmung nach Komfort und Entspannung erhöht wird. Die wesentlichen Maße dieses Modells drücken sich in einem modernen und entspannenden Design, das sich perfekt in moderne und funktionale Umgebungen einbettet, aus.

designed and dressed by
Alessandro Castello • Maria Antonietta Lagravinese

















YOKO 1 • YOKO 2



IT • Stile giovane e contemporaneo. Per chi ama stendersi e non semplicemente sedersi in modo tradizionale. I cuscini di schienale ed i braccioli si spostano a piacimento per dare ad ognuno il comfort preferito nelle più disparate situazioni. Si adatta facilmente alla funzione di letto occasionale. YOKO 1 è il modello con piedi bassi, YOKO 2 è dotato di piedini alti in metallo disponibili in diverse finiture.

EN • Young and contemporary style. For those who love to lie down and not just sit in a traditional way. Back cushions and armrests can be moved as you like to give everyone the favorite comfort in any situations. It can have the function of occasional bed. YOKO 1 is the model with low feet, YOKO 2 is equipped with high metal feet available with different finishings.

FR • Un style jeune et contemporaine. Pour ceux qui aiment se coucher plus que s'asseoir de la manière traditionnelle. Les coussins de dos et les accoudoirs s'adaptent sans problème au confort choisi. Facilement convertible en lit occasionnel. YOKO 1 a les pieds bas, YOKO 2 a les pieds hauts en métal, disponibles en plusieurs finitions.

D • Junger und kontemporär Stil. Für diejenigen, die sich hinlegen und nicht nur auf traditionelle Weise sitzen mögen. Die Rückkissen und Armlehnen stellen nach Belieben für jeden Komfort in vielen unterschiedlichen Situationen um. Es passt sich der Funktion eines gelegentlichen Bettes. YOKO 1 ist das erste Modell mit niedrigem Fuß, YOKO 2 ist mit hohen Füßen aus Metall in verschiedenen Feinbearbeitungen versehen.

designed and dressed by
Alessandro Castello • Maria Antonietta Lagravinese





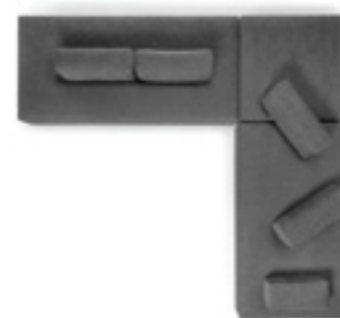
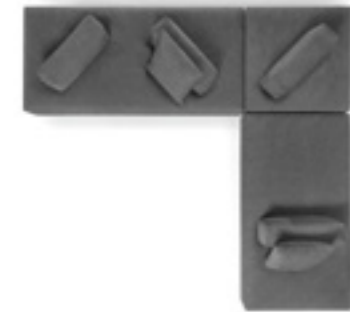





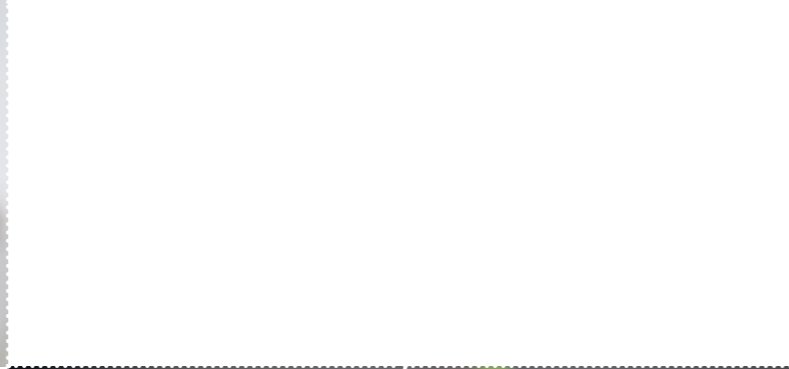

POLTRONE • ARMCHAIRS



GOSSIP



IT • Una poltrona moderna realizzata con imbottiture generose e decise in cui la proporzione e l'equilibrio tra la seduta e lo schienale creano un'estetica dal fascino misterioso. La particolare realizzazione dell'imbottitura richiama al mondo orientale degli origami, in cui la forma finale, apparentemente semplice, esalta in realtà una tecnica di lavorazione complessa e raffinata.

Un comfort avvolgente per una poltrona dall'estetica originalissima, che si offre come prodotto informale e contemporaneo. Unione perfetta tra design casual e finiture raffinate e contemporanee. In gamma è presente anche un pouff.

EN • A modern armchair with ample padding, where the proportion and balance between the seat and back create a mysteriously fascinating style. The special production of the padding recalls the oriental culture of origami, where the final, seemingly simple shape, exalts a highly complex and refined working method. Embracing comfort for a very original armchair, an informal and contemporary item. A perfect union between casual design and refined, contemporary finishes. In the range also a pouf is included.

FR • Un fauteuil moderne, réalisé avec des rembourrages généreux et affirmés, dans lequel la proportion et l'équilibre entre l'assise et le dossier créent une esthétique au charme mystérieux. Le rembourrage particulier rappelle le monde oriental des origamis, où la forme finale, simple en apparence, exalte en réalité une technique de fabrication complexe et raffinée. Un confort enveloppant pour un fauteuil à l'esthétique très originale, qui se propose comme un produit informel et contemporain. Il est l'union parfaite entre le design décontracté et des finitions raffinées et contemporaines. La gamme comprend aussi un pouf.

D • Ein moderner Sessel mit großzügiger und entschiedener Polsterung. Die Proportionen und die Harmonie zwischen Sitzfläche und Rückenlehne schaffen ein Design, das mit seinem geheimnisvollen Charme besticht. Die besondere Machart der Polsterung inspiriert sich an der orientalischen Origami-Kunst, wo die fertige Form einfach erscheint, in Wahrheit aber eine komplexe und schwierige Verarbeitung erforderlich macht. Behaglicher Komfort für einen Sessel mit ausgesprochen originellem Design, der sich als lässiges und modernes Möbelstück präsentiert. Die perfekte Verbindung vom Casual-Design und den eleganten und modernen Oberflächen. Die Serie beinhaltet auch den Hocker.

designed and dressed by
Alessandro Castello • Maria Antonietta Lagravinese













JAMMIN• JAMMIN LARGE



IT • Una poltrona dalle linee morbide e avvolgenti, capace di integrarsi in ambienti moderni o classici grazie al suo stile pulito e alle linee senza tempo. La poltrona Jammin può essere fissa o girevole ed è disponibile sia con schienale sagomato che, nella versione large, con schienale più avvolgente, entrambi espressione della continua ricerca di comfort. In gamma è presente anche un pouff.

EN • A soft and embracing armchair, ideal in modern or classic interiors thanks to its clean and timeless style. Jammin (swivel or fix) is available with a shaped back or a more enveloping back in the large version, both interpreting a continuous research into comfort. In the range also a pouf is included.

FR • Un fauteuil aux lignes douces et enveloppantes, en mesure de s'intégrer dans des pièces modernes ou classiques grâce à son style épuré et ses lignes intemporelles. Le fauteuil Jammin (fixe ou tournant) est disponible avec un dossier profilé ou, dans sa version large, avec un dossier plus enveloppant, tous les deux expression de la recherche continue de confort. La gamme comprend aussi un pouff.

D • Ein Sessel mit weichen und behaglichen Formen, der sich mit seinem sauberen Stil und dem zeitlosen Design harmonisch in moderne oder klassische Einrichtungen einfügt. Der Sessel Jammin ist sowohl mit geformter Rückenlehne als auch in der Version Large mit sehr komfortabler Rückenlehne erhältlich, beide Ergebnis der ständigen Optimierung vom Sitzkomfort. Die Serie beinhaltet auch den Hocker.

designed and dressed by
Alessandro Castello • Maria Antonietta Lagravinese















FENDER



IT • La poltrona Fender disegna lo spazio con la sua silhouette sottile ed armoniosa. Disponibile con basamento girevole oppure con eleganti piedi d'appoggio in abbinamento alla struttura in diverse finiture.

EN • The Fender armchair designs the space with its slender and harmonious silhouette. Available with a swivel base or elegant feet matched to the structure with different finishings.

FR • Le fauteuil Fender dessine l'espace avec sa silhouette fine et harmonieuse. Disponible avec un piètement pivotant ou avec d'élégants pieds d'appui en association avec la structure dans différentes finitions.

D • Der Sessel Fender gestaltet den Raum mit seiner schlanken und harmonischen Form. Erhältlich mit Drehgestell oder mit eleganten Füßen, die auf das Gestell in verschiedenen Feinbearbeitungen abgestimmt sind.

designed and dressed by
Alessandro Castello • Maria Antonietta Lagravinese















TAVOLINI • SMALL TABLES

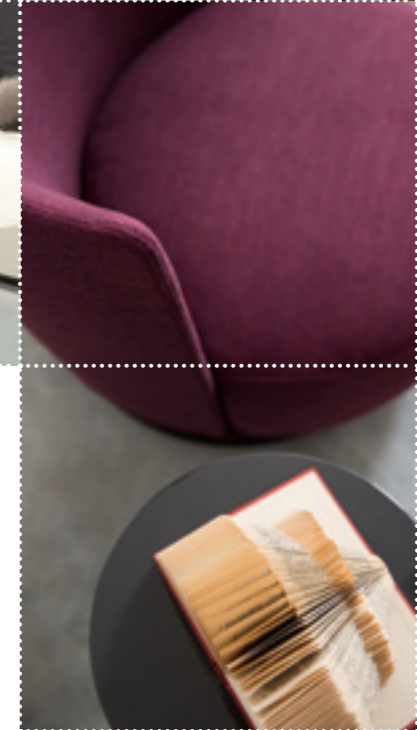



JAGGER

PHIL

HUGO

JAGGER

BABAR

FRISCO

JAGGER



IT • Una serie di tavolini dall'estetica futuristica, giocano sull'insolito numero delle gambe d'appoggio. Il piano e i cinque esili sostegni che lo compongono, laccati in diverse varianti colore, sembrano dare vita a personaggi sopraggiunti da altri mondi, per arredare lo spazio con eleganza e modernità.

EN • A series of futuristic side tables, playing on the unusual number of legs. The top and five narrow legs are lacquered in different colours and look like creatures from another planet, furnishing the room with modern elegance.

FR • Une série de tables basses, à l'esthétique futuriste, qui jouent sur le nombre insolite de pieds d'appui. Son plateau et ses cinq soutiens fins, laqués dans variantes mode, semblent donner vie à des personnages venus d'ailleurs, pour aménager l'espace avec élégance et modernité.

D • Eine Serie Beistelltische mit futuristischem Design, das mit der ungewöhnlichen Anzahl an Tischbeinen spielt. Die Tischplatte und die fünf zierlichen Tischbeine, die mit Lackierung in verschiedenen Farben erhältlich sind, verleihen einer Persönlichkeit Leben, die aus einer anderen Welt zu stammen scheint, und richten den Raum mit eleganter Modernität ein.

designed and dressed by
Alessandro Castello • Maria Antonietta Lagravinese











BABAR



IT • Un tavolino ironico e versatile, realizzato con due volumi sovrapposti dalle finiture moderne. Le due metà che lo costituiscono, separate da un taglio obliquo, sembrano scorrere l'una sull'altra, creando un equilibrio visivo molto insolito. Un prodotto dall'estetica forte realizzato per ambienti audaci, disponibile in diverse varianti di colore.

EN • An ironic versatile side table, made from two overlapping forms with modern finishes. The two halves are separated by an oblique line, and seem to slide into each other creating a very unusual visual balance. A strongly impacting item for bold interiors, available in different colours.

FR • Une table basse ironique et polyvalente, réalisée avec deux volumes superposés aux finitions modernes. Les deux moitiés qui la constituent sont séparées par une coupe oblique et semblent glisser l'une sur l'autre, créant un équilibre visuel très insolite. Un produit au fort impact esthétique, réalisé pour des pièces audacieuses, disponible en différentes couleurs.

D • Ein ironischer und vielseitiger Beistelltisch mit zwei übereinander angeordneten Elementen und moderner Oberfläche. Die beiden Tischhälften sind durch einen schrägen Schnitt voneinander getrennt und erwecken den Eindruck, als würden sie übereinander laufen. Diese Anordnung gibt dem Tisch sein sehr außergewöhnliches Aussehen. Ein Tisch mit starkem Charakter für gewagte Einrichtungen, erhältlich in verschiedenen Farben.

designed and dressed by
Alessandro Castello • Maria Antonietta Lagravinese













PHIL



IT • Un pratico tavolino ausiliario, progettato per scivolare con discrezione sotto i divani della collezione BLACK e offrire in ogni momento una base d'appoggio funzionale. Disponibile con piano in marmo o laccato e piedi in metallo in diverse finiture.

EN • A practical side table, designed to slide discreetly under the BLACK range of sofas, becoming a practical table whenever it is needed. The top is available in marble or lacquered, and with metal feet in different finishings.

FR • Une table basse auxiliaire pratique, conçue pour glisser avec discrétion sous les canapés de la collection BLACK et offrir à tout moment une base d'appui fonctionnelle. Disponible avec plateau en marbre ou laqué et pieds en métal dans différentes finitions.

D • Ein praktischer Beistelltisch, der sich diskret unter die Sofas der Kollektion BLACK schieben lässt und jederzeit als praktische Ablage genutzt werden kann. Erhältlich mit Tischplatte aus Marmor ou lackiert, und Metallfüßen, die in verschiedenen Feinbearbeitungen erhältlich sind.

designed and dressed by
Alessandro Castello • Maria Antonietta Lagravinese













FRISCO



IT • La serie di tavolini Frisco è caratterizzata da un doppio piano d'appoggio, sorretto da una struttura in metallo leggera ed estremamente raffinata, disponibile in diverse finiture.

La differenziazione dei due piani, superiore in marmo o laccato e inferiore laccato, consente la creazione di tavolini adatti ad ogni tipo di ambiente, giocando con l'accostamento di materiali insoliti e colori inconsueti.

EN • The Frisco range of side tables have a double top, supported by a lightweight, refined metal structure, available in different finishings. The different tops, upper in marble or lacquered, the lower lacquered, mean these tables can blend into any interior, playing with matching unusual materials and colours.

FR • La série de tables basses Frisco se caractérise par un double plateau, soutenu par une structure en métal légère et extrêmement raffinée, disponible dans différentes finitions. La différenciation des deux plateaux, en marbre ou laqué pour le plateau supérieur et laqué pour le plateau inférieur, permet de créer des tables basses adaptées à tout type de pièce, en jouant sur l'association de matériaux et de couleurs insolites.

D • Die Serie der Beistelltische Frisco ist durch die doppelte Ablagefläche und das leichte und extrem elegante Metallgestell charakterisiert, das in verschiedenen Feinbearbeitungen erhältlich ist. Die unterschiedliche Ausführung der beiden Ablageflächen - die Tischplatte ist aus Marmor oder lackiert, die untere Ablage lackiert, spielt mit der Kombination aus ungewöhnlichen Materialien und auffallenden Farben und macht die Beistelltisch ideal für jeden Einrichtungsstil.

designed and dressed by
Alessandro Castello • Maria Antonietta Lagravinese

















HUGO



IT • Il tavolino centrale Hugo è realizzato con due volumi traslati di diversa altezza, offrendo la possibilità di contrapporre finiture diverse in un gioco raffinato di colori, linee e geometrie.

La combinazione di più moduli accostati permette di giocare liberamente con lo spazio davanti al divano, realizzando un'unica superficie compatta rettangolare oppure un unico lungo piano d'appoggio.

EN • The Hugo central table is made with two different height forms, enabling overlapping different finishes in a refined play of colour, lines and shape. The modular combination enables playing with the space in front of the sofa, creating a single rectangular compact surface or a long top.

FR • La table basse centrale Hugo est réalisée avec deux volumes de différentes hauteurs, offrant la possibilité d'opposer des finitions différentes dans un jeu raffiné de couleurs, de lignes et de géométries. La combinaison de plusieurs modules permet de jouer librement avec l'espace devant le canapé, en réalisant une surface unique, compacte et rectangulaire ou un unique et long plateau.

D • Der Beistelltisch Hugo besteht aus zwei verschobenen Elementen unterschiedlicher Höhe, für die verschiedene Oberflächen kombiniert werden können, um mit Farben, Linien und Geometrien einen eleganten Effekt zu erzielen. Durch die Kombination mehrerer Module kann der Raum vor dem Sofa frei gestaltet und eine kompakte rechteckige Oberfläche oder eine einzige lange Ablage geschaffen werden.

designed and dressed by
Alessandro Castello • Maria Antonietta Lagravinese





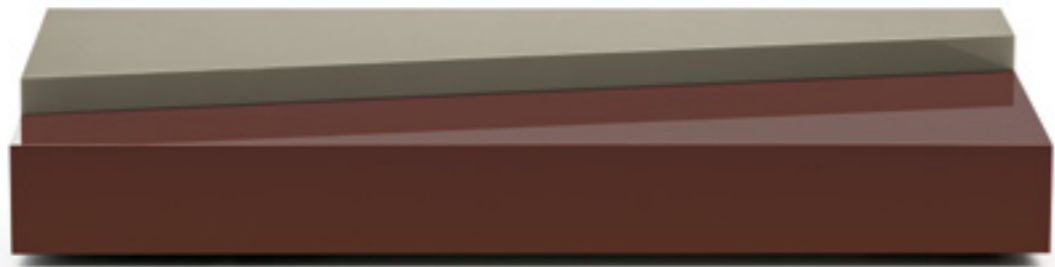





RIEPILOGO • SUMMARY



FLOYD • FLOYD 120 DEEP



12 13

FLOYD divano/sofa/canapé/sofa
 • 01FLDC5 (1FLDC1SX - 1FLDCHLLDX) • 8149 Jasper magnolia, Cat. 8
JAGGER 35 tavolino/small table/table/Couchtisch ø 35
 • 1JAGTH • Dove Grey
JAGGER 50 tavolino/small table/table/Couchtisch ø 50
 • 1JAGTL • Green
PHIL tavolino/small table/table/Couchtisch
 • 1PHISER • marmo/marble/marbre/Marmor Magic Brown, Cat. X1
 • struttura/structure/structure/Struktur French Bronze

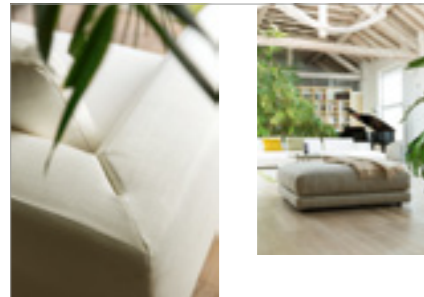
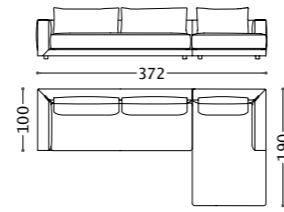

14 15

FLOYD pouff/pouf/pouf/Hocker
 • 1FLDPF120 • 7142 Axinit corda, Cat. 7

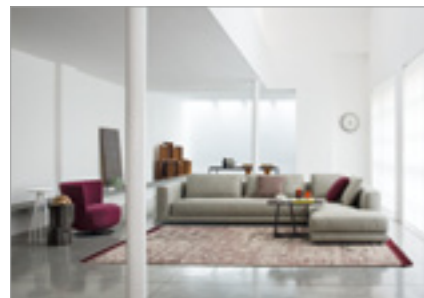
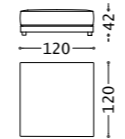

16 17

FLOYD divano/sofa/canapé/sofa
 • 01FLDC3 (1FLDC1SX-1FLDMERDX) • 526C Mawi Corda, Cat. 5
JAMMIN LARGE poltrona girevole/swivel armchair/fauteuil tournant/Drehsessel
 • 1JAMPLG • 5351 Spirit ciliegia, Cat. 5 • basamento/base/piètement/Basis Gun Metal
JAGGER 35 tavolino/small table/table/Couchtisch ø 35
 • 1JAGTH • Ivory
PHIL tavolino/small table/table/Couchtisch
 • 1PHISER • Mink brown • struttura/structure/structure/Struktur Gun Metal
BABAR tavolino/small table/table/Couchtisch
 • 1BBRTROT • Mink brown

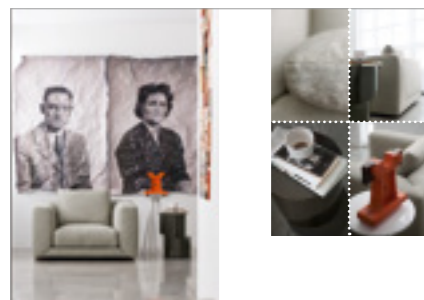
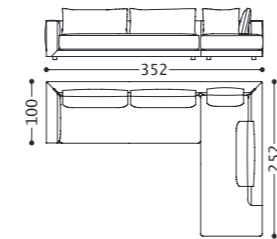

22 23

FLOYD poltrona/armchair/fauteuil/Sessel
 • 1FLDP • 526C Mawi Corda, Cat. 5
BABAR tavolino/small table/table/Couchtisch
 • 1BBRTROT • Mink brown
JAGGER 35 tavolino/small table/table/Couchtisch ø 35
 • 1JAGTH • Ivory

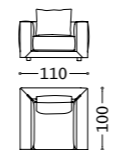

24 25

FLOYD divano/sofa/canapé/Sofa
 • 1FLDESPDX • 7145 Blenda talpa, Cat. 7
FLOYD tavolino/small table/table/Couchtisch
 • 1FLTAVTS • Marquina Black, Cat. X2
FENDER poltrona girevole/swivel armchair/fauteuil tournant/Drehsessel
 • 1FENPAG • 7143 Blenda Orchidea Cat. 7
 • basamento/base/piètement/Basis Gun Metal
JAGGER 35 tavolino/small table/table/Couchtisch ø 35
 • 1JAGTH • Blue
JAGGER 75 tavolino/small table/table/Couchtisch ø 75
 • 1JAGTM • Bordeaux
BABAR tavolino/small table/table/Couchtisch
 • 1BBRTROT • Grey
HUGO tavolino/small table/table/Couchtisch
 • 0HUGC1 (1HUGTH-1HUGTL) • Grey - Bordeaux

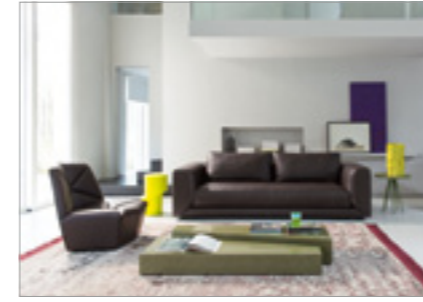
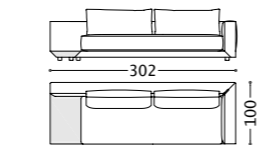

26 27

FLOYD divano/sofa/canapé/Sofa
 • 2FLDB1 • 942 Fjord Dark Brown, Cat. G
GOSSIP poltrona/armchair/fauteuil/Sessel
 • 2GSPP • 942 Fjord Dark Brown, Cat. G
JAGGER 50 tavolino/small table/table/Couchtisch ø 50
 • 1JAGTL • Green
BABAR tavolino/small table/table/Couchtisch
 • 1BBRTROT • Yellow Fluo
HUGO tavolino/small table/table/Couchtisch
 • 0HUGC1 (1HUGTH-1HUGTL) • Green

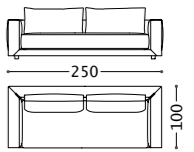

28 29

FLOYD divano/sofa/canapé/Sofa
 • 02FLDC2 (2FLDB1SX-2FLDCHLSDX) • 9M12 Tender Ecru, Cat. H
FRISCO 50 tavolino/small table/table/Couchtisch ø 50
 • 1FRITROT • Top 1 marmo/marble/marbre/Marmor Magic Brown, Cat. X3 • Top 2 Dove Grey
 • struttura/structure/structure/Struktur Gun Metal
BABAR tavolino/small table/table/Couchtisch
 • 1BBRTROT • Dove Grey

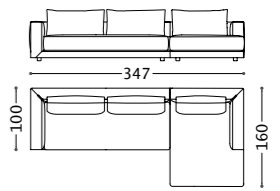

30 31

FLOYD divano/sofa/canapé/Sofa
 • 1FLDESPSX • 6125 Tara Grigio Chiaro, Cat. 6
FLOYD 120 DEEP divano/sofa/canapé/Sofa
 • 1FLDESPPRDX • 6125 Tara Grigio Chiaro, Cat. 6
FLOYD tavolino/small table/table/Couchtisch
 • 1FLTAVAPSX • marmo/marble/marbre/Marmor Marquina Black, Cat. X2
GOSSIP poltrona/armchair/fauteuil/Sessel
 • 1GSPP • 8198 Ginny Shocking, Cat. 8
FRISCO 75 tavolino/small table/table/Couchtisch 75x75
 • 1FRITAVQA • Top 1 marmo/marble/marbre/Marmor Calacatta White, Cat. X4 • Top 2 Bordeaux
 • struttura/structure/structure/Struktur French Bronze
JAGGER 75 tavolino/small table/table/Couchtisch ø 75
 • 1JAGTM • Bordeaux
HUGO tavolino/small table/table/Couchtisch
 • 0HUGC1 (1HUGTH-1HUGTL) • Grey
HUGO tavolino/small table/table/Couchtisch
 • 0HUGC1 (1HUGTH-1HUGTL) • Grey-Bordeaux

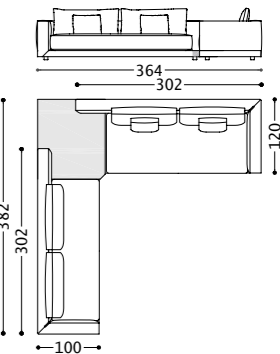

34 35

FLOYD divano/sofa/canapé/Sofa
 • 1FLDB1 • 7145 Blenda Talpa, Cat. 7
FLOYD 120 DEEP divano/sofa/canapé/Sofa
 • 1FLDB1P • 6125 Tara Grigio Chiaro, Cat. 6

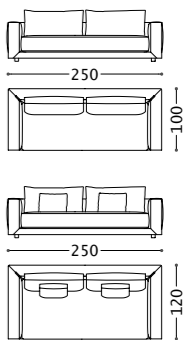

FLOYD • FLOYD 120 DEEP

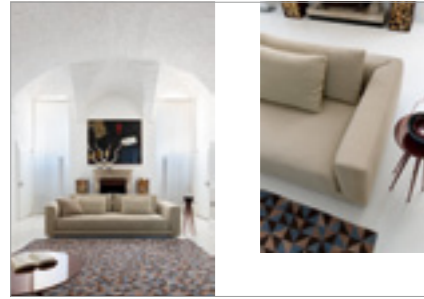

36 37

FLOYD 120 DEEP divano/sofa/canapé/Sofa
 • 1FLDC1P • 600A Linux Greggio, Cat.6
JAGGER 35 tavolino/small table/table/Couchtisch ø 35
 • 1JAGTH • Bordeaux

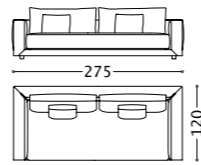

40 41

FLOYD divano/sofa/canapé/Sofa
 • 2FLDCHLC1TSX • 9G2 Nabuk Grigio, Cat.1
FLOYD tavolino/small table/table/Couchtisch
 • 1FLTTAVCM • marmo/marble/marbre/Marmor Marquina Black, Cat. X2
GOSSIP poltrona/armchair/fauteuil/Sessel
 • 1GSPP • 8198 Ginny Shocking, Cat. 8
PHIL tavolino/small table/table/Couchtisch
 • 1PHISER • marmo/marble/marbre/Marmor Marquina Black, Cat. X2
 • struttura/structure/structure/Struktur Gun Metal

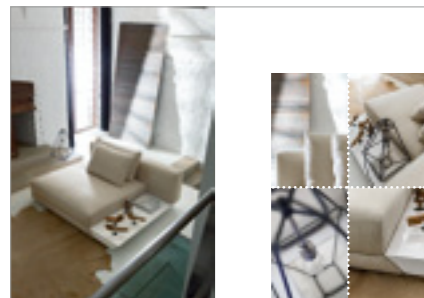
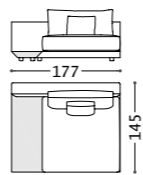

42 43

FLOYD divano/sofa/canapé/Sofa
 • 1FLDCHLC1TDX • 8119 Jasper Lino, Cat.8
FLOYD tavolino/small table/table/Couchtisch
 • 1FLTTAVCM • Ivory

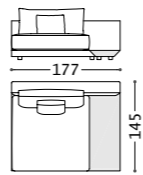

DYLAN



46 47

DYLAN divano/sofa/canapé/Sofa
 • 01DYLC7 (1DYL220SX-1DYL300-1DYL210DX)
 • 8199 Jasper Lino, Cat. 8 • piede/foot/pied/Fuß French Bronze
DYLAN pouff/pouf/pouf/Hocker
 • 2DYL290 • 9G1 Nabuk Sabbia, Cat. 1
 • piede/foot/pied/Fuß French Bronze
JAGGER 35 tavolino/small table/table/Couchtisch ø 35
 • 1JAGTH • Blue
JAGGER 50 tavolino/small table/table/Couchtisch ø 50
 • 1JAGTL • Bordeaux
JAGGER 75 tavolino/small table/table/Couchtisch ø 75
 • 1JAGTM • Blue

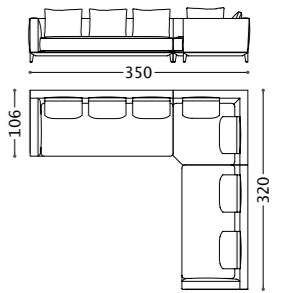

50 51

DYLAN divano/sofa/canapé/Sofa
 • 1DYL230 • 6955 Sfaleri Sabbia, Cat. 6 • piede/foot/pied/Fuß French Bronze

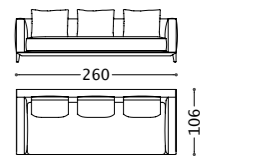

52 53

DYLAN divano/sofa/canapé/Sofa
 • 01DYLC1 (1DYL230SX-1DYL270DX) • 6955 Sfaleri Sabbia, Cat. 6
 • piede/foot/pied/Fuß French Bronze
PHIL tavolino/small table/table/Couchtisch
 • 1PHISER • marmo/marble/marbre/Marmor Calacatta White, Cat. X4
 • struttura/structure/structure/Struktur French Bronze

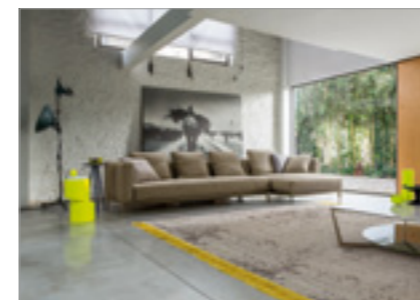
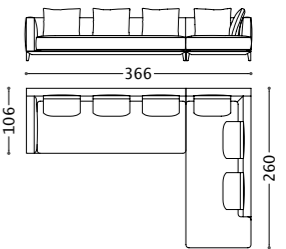

54 55

DYLAN divano/sofa/canapé/Sofa
 • 01DYLC6 (1DYL230SX-1DYL280DX) • 7152 Axinit Beige, Cat. 7
 • piede/foot/pied/Fuß French Bronze
FRISCO 120 tavolino/small table/table/Couchtisch 120x120
 • 1FRITAVQB • Top 1 marmo/marble/marbre/Marmor Calacatta White, Cat. X4 • Top 2 Green • struttura/structure/structure/Struktur French Bronze
JAGGER 35 tavolino/small table/table/Couchtisch ø 35
 • 1JAGTH • Blue
BABAR tavolino/small table/table/Couchtisch
 • 1BBRTROT • Yellow Fluo

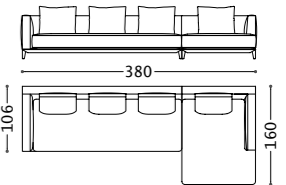

58 59

DYLAN divano/sofa/canapé/Sofa
 • 01DYLC4 (1DYL200SX-1DYL200DX) • 6051 Arizona Polvere, Cat.6
 • piede/foot/pied/Fuß Gun Metal
FENDER poltrona/armchair/fauteuil/Sessel
 • 2FENPA • 9C1 Sensation Creta, Cat.H • piede/foot/pied/Fuß Gun Metal
FRISCO 50 tavolino/small table/table/Couchtisch ø 50
 • 1FRITROT • Top 1 marmo/marble/marbre/Marmor Calacatta White, Cat. X4 • Top 2 Blue • struttura/structure/structure/Struktur French Bronze
FRISCO 75 tavolino/small table/table/Couchtisch 75x75
 • 1FRITAVQA • Top 1 marmo/marble/marbre/Marmor Calacatta White, Cat. X4 • Top 2 Green • struttura/structure/structure/Struktur French Bronze
JAGGER 75 tavolino/small table/table/Couchtisch ø 75
 • 1JAGTM • Bordeaux

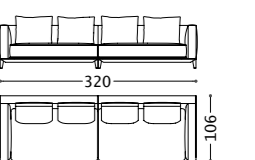

BOWIE



62 63

BOWIE divano/sofa/canapé/Sofa
 • 2BOW230 • 942 Fjord Dark Brown, Cat. G • piede/foot/pied/Fuß Gun Metal
BOWIE poltrona/armchair/fauteuil/Sessel
 • 2BOW310 • 942 Fjord Dark Brown, Cat. G • piede/foot/pied/Fuß Gun Metal
FRISCO 75 tavolino/small table/table/Couchtisch 75x75
 • 1FRITAVQA • Top 1 marmo/marble/marbre/Marmor Calacatta White, Cat. X4 • Top 2 Bordeaux • struttura/structure/structure/Struktur French Bronze
PHIL tavolino/small table/table/Couchtisch
 • 1PHISER • marmo/marble/marbre/Marmor Calacatta White, Cat. X4 • struttura/structure/structure/Struktur French Bronze

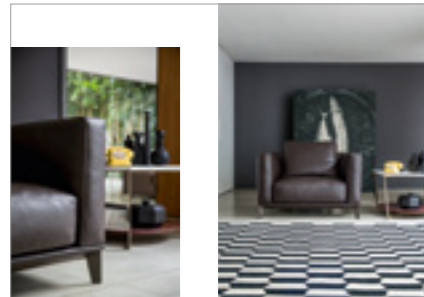
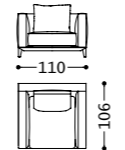
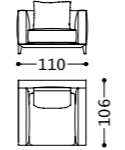
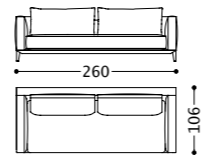

66 67

BOWIE poltrona/armchair/fauteuil/Sessel
 • 2BOW310 • 942 Fjord Dark Brown, Cat. G • piede/foot/pied/Fuß Gun Metal
FRISCO 75 tavolino/small table/table/Couchtisch 75x75
 • 1FRITAVQA • Top 1 marmo/marble/marbre/Marmor Calacatta White, Cat. X4 • Top 2 Bordeaux • struttura/structure/structure/Struktur French Bronze



68 69

BOWIE divano/sofa/canapé/Sofa
 • 01BOWC14 (1BOW271SX -1BOW220DX) • 7083 Matilda Segale, Cat.7 - 612E Eco Club Fango, Cat. 6 • piede/foot/pied/Fuß French Bronze
JAGGER 35 tavolino/small table/table/Couchtisch ø 35
 • 1JAGTH • Green
JAGGER 75 tavolino/small table/table/Couchtisch ø 75
 • 1JAGTM • Blue
HUGO tavolino/small table/table/Couchtisch
 • 0HUGC1 (1HUGTH-1HUGTL) • Green
HUGO tavolino/small table/table/Couchtisch
 • 1HUGTH • Green
BABAR tavolino/small table/table/Couchtisch
 • 1BBRTROT • Yellow Fluo

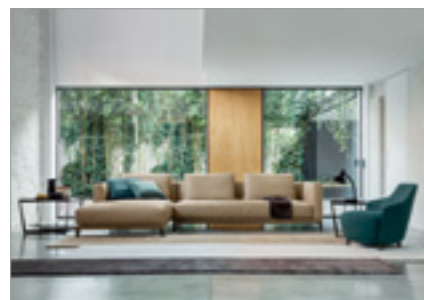
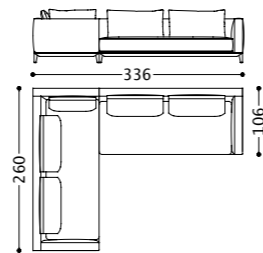

72 73

BOWIE divano/sofa/canapé/Sofa
 • 02BOWC15 (2BOW281SX-2BOW220DX) • 954 Fjord Sand, Cat.G • piede/foot/pied/Fuß Gun Metal
JAMMIN poltrona/armchair/fauteuil/Sessel
 • 1JAMP • 6133 Tara Smeraldo, Cat.6 • piede/foot/pied/Fuß Gun Metal
FRISCO 75 tavolino/small table/table/Couchtisch 75x75
 • 1FRITAVQA • Top 1 marmo/marble/marbre/Marmor Marquina Black, Cat. X2 • Top 2 Grey • struttura/structure/structure/Struktur Gun Metal
FRISCO 50 tavolino/small table/table/Couchtisch ø 50
 • 1FRITROT • Top 1 marmo/marble/marbre/Marmor Marquina Black, Cat. X2 • Top 2 Grey • struttura/structure/structure/Struktur Gun Metal

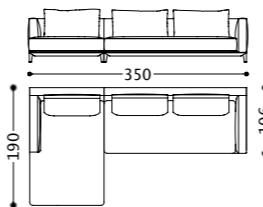

CINDY



78 79

CINDY divano/sofa/canapé/Sofa
 • 1CIN130 • 571B Giava Ecrú', Cat. 5
FENDER poltrona girevole/swivel armchair/fauteuil tournant/Drehsessel
 • 1FENPAG • 5339 Spirit Terra Cat. 5 • basamento/base/piétement/Basis French Bronze
FRISCO 50 tavolino/small table/table/Couchtisch ø 50
 • 1FRITROT • Top 1 marmo/marble/marbre/Marmor Calacatta White, Cat. X4 • Top 2 Dove Grey • struttura/structure/structure/Struktur French Bronze
JAGGER 35 tavolino/small table/table/Couchtisch ø 35
 • 1JAGTH • Bordeaux

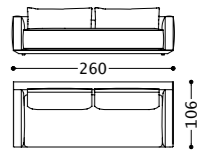

80 81

CINDY divano/sofa/canapé/Sofa
 • 1CIN130 • 6051 Arizona Polvere, Cat. 6
CINDY divano/sofa/canapé/Sofa
 • 1CIN130 • 571B Giava Ecrú', Cat. 5
JAGGER 35 tavolino/small table/table/Couchtisch ø 35
 • 1JAGTH • Bordeaux

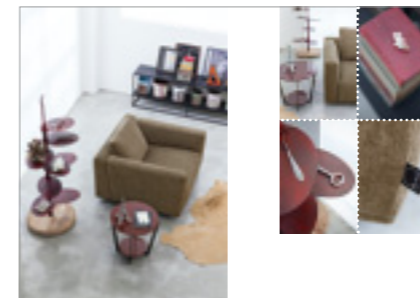
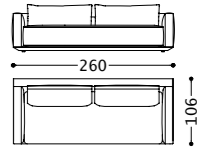

84 85

CINDY poltrona/armchair/fauteuil/Sessel
 • 1CIN310 • 413F Litos Muschio, Cat. 4
FRISCO 50 tavolino/small table/table/Couchtisch ø 50
 • 1FRITROTL • Top 1 Bordeaux • Top 2 Bordeaux • struttura/structure/structure/Struktur Gun Metal

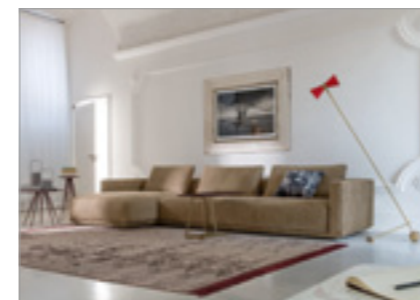
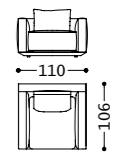

86 87

CINDY divano/sofa/canapé/Sofa
 • 02CINC16 (2CIN180SX -2CIN130DX) • 9M15 Tender Mud, Cat. H
JAGGER 35 tavolino/small table/table/Couchtisch ø 35
 • 1JAGTH • Bordeaux
JAGGER 75 tavolino/small table/table/Couchtisch ø 75
 • 1JAGTM • Bordeaux
PHIL tavolino/small table/table/Couchtisch
 • 1PHISERL • Bordeaux • struttura/structure/structure/Struktur French Bronze

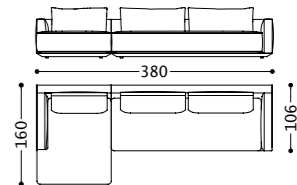

RONNY



92 93

RONNY divano/sofa/canapé/Sofa
 • 1RNN230 • 6955 Sfaleri Sabbia, Cat. 6 • piede/foot/pied/Fuß French Bronze
JAMMIN poltrona/armchair/fauteuil/Sessel
 • 2JAMP • 9M16 Tender Cherry, Cat.H • piede/foot/pied/Fuß French Bronze
HUGO tavolino/small table/table/Couchtisch
 • 0HUGC1 (1HUGTH-1HUGTL) • Blue-Bordeaux

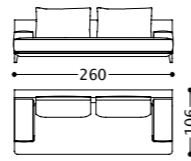

94 95

RONNY divano/sofa/canapé/Sofa
 • 2RNN230 • 8C2 Dakota Ice • piede/foot/pied/Fuß French Bronze
RONNY divano/sofa/canapé/Sofa
 • 1RNN230 • 6955 Sfaleri Sabbia, Cat. 6 • piede/foot/pied/Fuß French Bronze

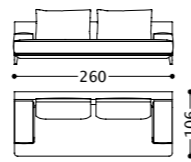

96 97

RONNY divano/sofa/canapé/Sofa
 • 01RNNC11 (1RNN230SX-1RNN260DX) • 6131 Tara Grigio Scuro, Cat. 6 - 612N Eco Club Grigio Oliva, Cat. 6 • piede/foot/pied/Fuß Gun Metal
GOSSIP poltrona/armchair/fauteuil/Sessel
 • 1GSPP • 7151 Blenda Prussia, Cat. 7
FRISCO 75 tavolino/small table/table/Couchtisch 75x75
 • 1FRITROT • Top 1 marmo/marble/marbre/Marmor Marquina Black, Cat. X2 • Top 2 Grey • struttura/structure/structure/Struktur Gun metal
PHIL tavolino/small table/table/Couchtisch
 • 1PHISER • marmo/marble/marbre/Marmor Marquina Black, Cat. X2 • struttura/structure/structure/Struktur Gun metal
BABAR tavolino/small table/table/Couchtisch
 • 1BBRTROT • Yellow Fluo

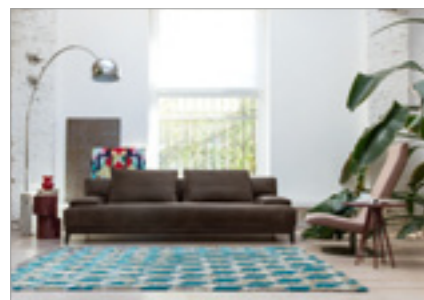
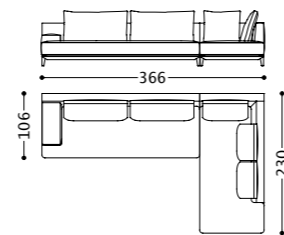

104 105

RONNY divano/sofa/canapé/Sofa
 • 2RNN230 • 9C3 Sensation T. moro, Cat. H • piede/foot/pied/Fuß Gun Metal
FENDER poltrona girevole/swivel armchair/fauteuil tournant/Drehsessel
 • 1FENPAG • 7143 Blenda Orchidea cat. 7 • basamento/base/piétement/Basis Gun Metal
JAGGER 50 tavolino/small table/table/Couchtisch ø 50
 • 1JAGTL • Bordeaux
BABAR tavolino/small table/table/Couchtisch
 • 1BBRTROT • Bordeaux

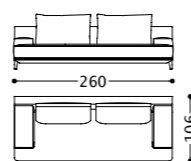

108 109

RONNY poltrona/armchair/fauteuil/Sessel
 • 1RNN310 • 6955 Sfaleri Sabbia- 6956 Sfaleri Greige, Cat. 6 • piede/foot/pied/Fuß French Bronze
BABAR tavolino/small table/table/Couchtisch
 • 1BBRTROT • Blue

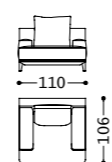

MORRISON



112 113

MORRISON divano/sofa/canapé/Sofa
 • 01MORC9 (1MOR110SX - 1MOR300 - 1MOR110DX) • 7150 Blenda Panna, Cat. 7
JAGGER 50 tavolino/small table/table/Couchtisch ø 50
 • 1JAGTL • Grey
BABAR tavolino/small table/table/Couchtisch
 • 1BBRTROT • Yellow fluo

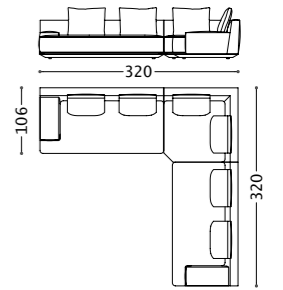

116 117

MORRISON divano/sofa/canapé/Sofa
 • 02MORC4 (2MOR100SX-2MOR100DX) • 9A1 Elite Testamoro, Cat. H
JAMMIN LARGE poltrona/armchair/fauteuil/Sessel
 • 1JAMPL • 6955 Sfaleri Sabbia, Cat.6 • piede/foot/pied/Fuß French Bronze
JAGGER 35 tavolino/small table/table/Couchtisch ø 35
 • 1JAGTH • Blue
FRISCO 50 tavolino/small table/table/Couchtisch ø 50
 • 1FRITROT • Top 1 marmo/marble/marbre/Marmor Calacatta White, Cat. X4 • Top 2 Blue • struttura/structure/structure/Struktur French Bronze
PHIL tavolino/small table/table/Couchtisch
 • 1PHISER • marmo/marble/marbre/Marmor Calacatta white, Cat. X4 • struttura/structure/structure/Struktur French Bronze
BABAR tavolino/small table/table/Couchtisch • 1BBRTROT • Blue

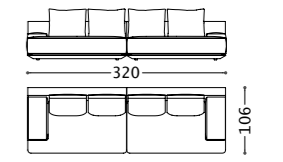

120 121

MORRISON divano/sofa/canapé/Sofa
 • 1MOR120 • 6125 Tara Grigio Chiaro, Cat. 6 - 612M Eco club Black, Cat. 6
MORRISON pouff/pouf/pouf/Hocker
 • 2MOR193 • 9C4 Sensation nero, Cat. H
JAMMIN poltrona/armchair/fauteuil/Sessel
 • 1JAMP • 8178 Zincy Ottanio, Cat.8 • piede/foot/pied/Fuß Gun metal
JAMMIN poltrona/armchair/fauteuil/Sessel
 • 1JAMP • 6133 Tara Smeraldo, Cat.6 • piede/foot/pied/Fuß Gun metal
FRISCO 50 tavolino/small table/table/Couchtisch ø 50
 • 1FRITROT • Top 1 marmo/marble/marbre/Marmor Marquina Black, Cat. X2 • Top 2 Grey • struttura/structure/structure/Struktur French Bronze
HUGO tavolino/small table/table/Couchtisch
 • 0HUGC1 (1HUGTH-1HUGTL) • Grey

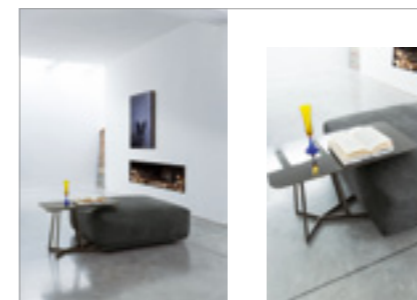
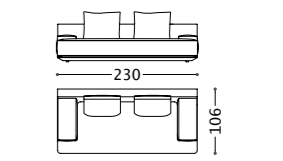

126 127

MORRISON pouff/pouf/pouf/Hocker • 2MOR193 • 9C4 Sensation nero, Cat. H
PHIL tavolino/small table/table/Couchtisch • 1PHISERL • Mink brown
 • struttura/structure/structure/Struktur Gun Metal

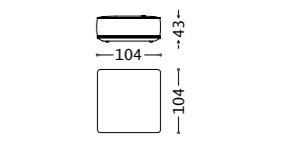

128 129

MORRISON divano/sofa/canapé/Sofa
 • 01MORC4 (1MOR100SX-1MOR100DX) • 6051 Arizona Polvere, Cat. 6
GOSSIP poltrona/armchair/fauteuil/Sessel
 • 1GSPP • 8199 Ginny Cobalto, Cat. 8
JAGGER 35 tavolino/small table/table/Couchtisch ø 35
 • 1JAGTH • Blue
JAGGER 75 tavolino/small table/table/Couchtisch ø 75
 • 1JAGTM • Bordeaux
BABAR tavolino/small table/table/Couchtisch
 • 1BBRTROT • Yellow Fluo
HUGO tavolino/small table/table/Couchtisch
 • 0HUGC1 (1HUGTH-1HUGTL) • Grey
HUGO tavolino/small table/table/Couchtisch
 • 0HUGC1 (1HUGTH-1HUGTL) • Grey-Bordeaux

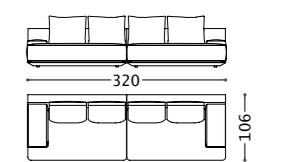

BRUCE



132

133

- BRUCE** divano/sofa/canapé/Sofa
 • 1BRU130 • 7151 Blenda Prussia, Cat. 7
JAMMIN LARGE poltrona/armchair/fauteuil/Sessel
 • 1JAMPL • 7151 Blenda Prussia, Cat. 7 • piede/foot/pied/Fuß French Bronze
FRISCO 50 tavolino/small table/table/Couchtisch ø 50
 • 1FRITROT • Top 1 marmo/marble/marbre/Marmor Calacatta White, Cat. X4 • Top 2 Blue • struttura/structure/structure/Struktur French Bronze
BABAR tavolino/small table/table/Couchtisch
 • 1BBRTROT • Blue

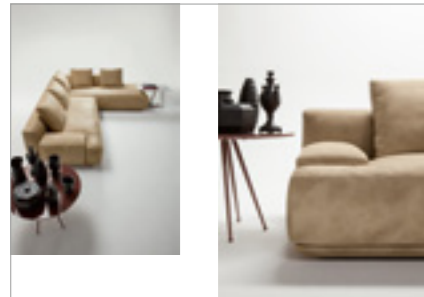
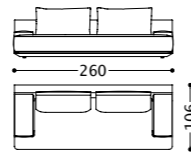

138

139

- BRUCE** divano/sofa/canapé/Sofa
 • 02BRUC2 (2BRU110SX-2BRU160DX) • 9M12 Tender Ecrù, Cat. H
JAGGER 75 tavolino/small table/table/Couchtisch ø 75
 • 1JAGTM • Bordeaux
PHIL tavolino/small table/table/Couchtisch
 • 1PHISER • marmo/marble/marbre/Marmor Calacatta white, Cat. X4
 • struttura/structure/structure/Struktur French Bronze

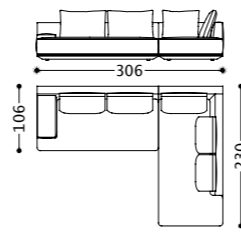

140

141

- BRUCE** divano/sofa/canapé/Sofa
 • 02BRUC3 (2BRU110SX + 2BRU180DX) • 8C2 Dakota Ice, Cat. F
JAGGER 35 tavolino/small table/table/Couchtisch ø 35
 • 1JAGTH • Grey
JAGGER 50 tavolino/small table/table/Couchtisch ø 50
 • 1JAGTL • Bordeaux
BABAR tavolino/small table/table/Couchtisch
 • 1BBRTROT • Bordeaux
HUGO tavolino/small table/table/Couchtisch
 • 0HUGC1 (1HUGTH-1HUGTL) • Grey-Bordeaux

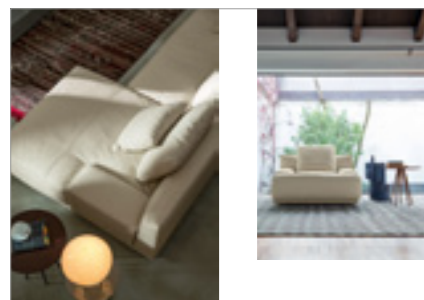
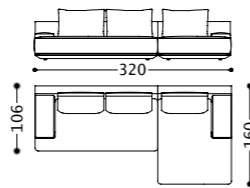

144

145

- BRUCE** divano/sofa/canapé/Sofa
 • 2BRU310 • 8C2 Dakota ice, Cat. F
JAGGER 50 tavolino/small table/table/Couchtisch ø 50
 • 1JAGTL • Bordeaux
BABAR tavolino/small table/table/Couchtisch
 • 1BBRTROT • Blue

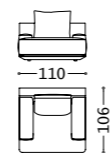

YOKO 1 • YOKO 2



146

147

- YOKO 2** divano/sofa/canapé/Sofa
 • 01YK2C3 (1YK2411 - 1YK2CSRT nr.2 - 1YK2CSH nr.2) • 411C Nuvola Fumo, Cat. 4 • piede/foot/pied/Fuß French Bronze
PHIL tavolino/small table/table/Couchtisch
 • 1PHISER • marmo/marble/marbre/Marmor Calacatta white, Cat. X4 • struttura/structure/structure/Struktur French Bronze

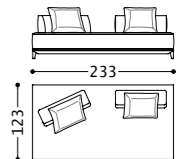

152

153

- YOKO 1** divano/sofa/canapé/Sofa
 • 01YK1C2 (1YK1411 - 1YK1431 - 1YK1421 - 1YK1CSRT nr.4 - 1YK1CSH nr.2 - 1YK1CBR) • 411C Nuvola Fumo, Cat. 4
GOSSIP poltrona/armchair/fauteuil/Sessel
 • 1GSPP • 8199 Ginny Cobalto, Cat. 8
HUGO tavolino/small table/table/Couchtisch
 • 1HUGTH-1HUGTH • Blue
BABAR tavolino/small table/table/Couchtisch
 • 1BBRTROT • Yellow Fluo

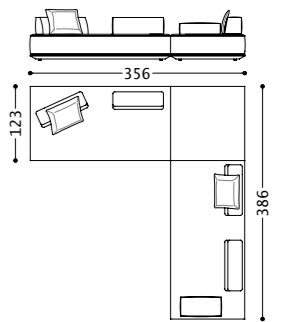

GOSSIP



158 159

GOSSIP poltrona/armchair/fauteuil/Sessel
 • 1GSPP • 8198 Ginny Shocking , Cat. 8
 FRISCO 75 tavolino/small table/table/Couchtisch 75x75
 • 1FRITAVQA • Top 1 marmo/marble/marbre/Marmor Calacatta White, Cat. X4 • Top 2 Bordeaux • struttura/structure/structure/Struktur French Bronze

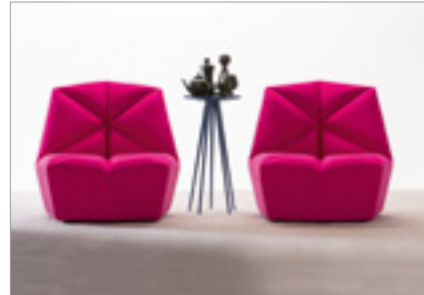
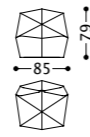

162 163

GOSSIP poltrona/armchair/fauteuil/Sessel
 • 1GSPP • 8198 Ginny Shocking , Cat. 8
 JAGGER 35 tavolino/small table/table/Couchtisch ø 35
 • 1JAGTH • Blue

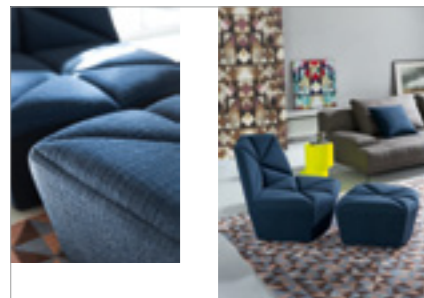
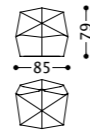

164 165

GOSSIP poltrona/armchair/fauteuil/Sessel
 • 1GSPP • 7151 Blenda Prussia, Cat.7
 GOSSIP pouff/pouf/pouf/Hocker
 • 1GSPPPOUFF • 7151 Blenda Prussia, Cat.7
 BABAR tavolino/small table/table/Couchtisch
 • 1BBRTROT • Yellow Fluo

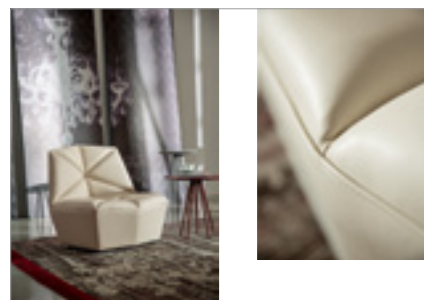
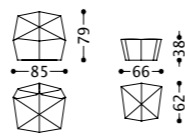

166 167

GOSSIP poltrona/armchair/fauteuil/Sessel
 • 2GSPP • 8C2 Dakota Ice, Cat. F
 JAGGER 50 tavolino/small table/table/Couchtisch ø 50
 • 1JAGTL • Bordeaux
 JAGGER 35 tavolino/small table/table/Couchtisch ø 35
 • 1JAGTH • Ivory

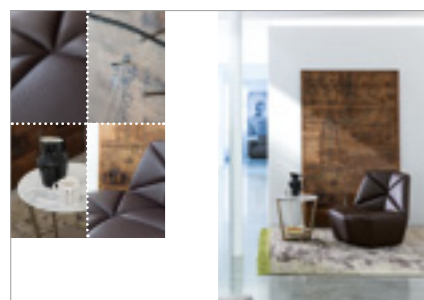
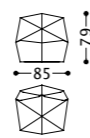

168 169

GOSSIP poltrona/armchair/fauteuil/Sessel
 • 2GSPP • 942 Fjord Dark Brown, Cat. G
 FRISCO 50 tavolino/small table/table/Couchtisch ø 50
 • 1FRITROT • Top 1 marmo/marble/marbre/Marmor Calacatta White, Cat. X4 • Top 2 Dove Grey • struttura/structure/structure/Struktur French Bronze

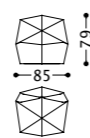

JAMMIN • JAMMIN LARGE



170 171

JAMMIN poltrona/armchair/fauteuil/Sessel
 • 2JAMP • 9M16 Tender Cherry, Cat. H • piede/foot/pied/Fuß French Bronze
 JAMMIN pouff/pouf/pouf/Hocker
 • 2JAMPOUFF • 9M16 Tender Cherry, Cat. H • piede/foot/pied/Fuß French Bronze
 JAGGER 50 tavolino/small table/table/Couchtisch ø 50
 • 1JAGTL • Bordeaux

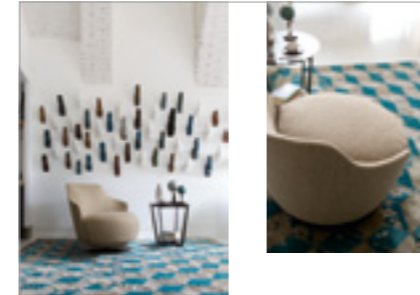
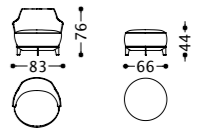

174 175

JAMMIN poltrona girevole/swivel armchair/fauteuil tournant/Drehsessel
 • 1JAMPG • 411D Nuvola Canapa, Cat. 4 • basamento/base/pièment/Basis Gun Metal
 FRISCO 50 tavolino/small table/table/Couchtisch ø 50
 • 1FRITROT • Top 1 marmo/marble/marbre/Marmor Magic Brown, Cat. X1 • Top 2 Dove Grey • struttura/structure/structure/Struktur Gun Metal

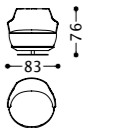

176 177

JAMMIN poltrona/armchair/fauteuil/Sessel
 • 2JAMP • 9A1 Elite testamoro, Cat. H • piede/foot/pied/Fuß French Bronze
 JAMMIN LARGE poltrona/armchair/fauteuil/Sessel
 • 1JAMPL • 6955 Sferi Sabbia, Cat. 6 • piede/foot/pied/Fuß French Bronze
 FRISCO 50 tavolino/small table/table/Couchtisch ø 50
 • 1FRITROT • Top 1 marmo/marble/marbre/Marmor Calacatta White, Cat. X4 • Top 2 Blue • struttura/structure/structure/Struktur French Bronze
 BABAR tavolino/small table/table/Couchtisch
 • 1BBRTROT • Blue

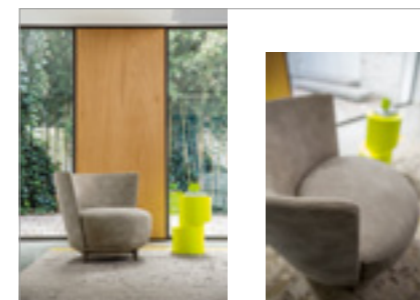
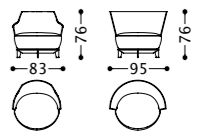

180 181

JAMMIN LARGE poltrona/armchair/fauteuil/Sessel
 • 2JAMPL • 9C1 Sensation creta, Cat. H • piede/foot/pied/Fuß French Bronze
 BABAR tavolino/small table/table/Couchtisch
 • 1BBRTROT • Yellow Fluo

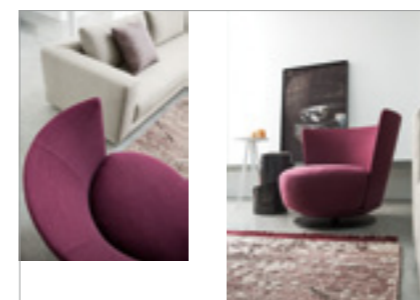
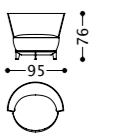

182 183

JAMMIN LARGE poltrona girevole/swivel armchair/fauteuil tournant/Drehsessel
 • 1JAMPLG • 5351 Spirit ciliegia, Cat. 5 • basamento/base/pièment/Basis Gun Metal
 JAGGER 35 tavolino/small table/table/Couchtisch ø 35
 • 1JAGTH • Ivory
 BABAR tavolino/small table/table/Couchtisch
 • 1BBRTROT • Mink brown

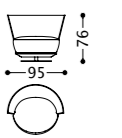

FENDER

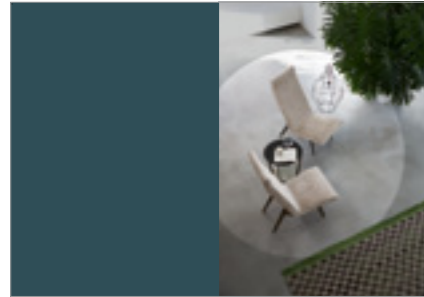

184

185

FENDER poltrona/armchair/fauteuil/Sessel
 • 1FENPA • 8196 Zincy grigio chiaro, Cat.8 • piede/foot/pied/Fuß Gun Metal
FRISCO 50 tavolino/small table/table/Couchtisch ø 50
 • 1FRITROT • Top 1 marmo/marble/marbre/Marmor Marquina Black, Cat. X2 • Top 2 Grey • struttura/structure/structure/Struktur Gun Metal

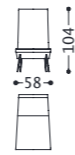

186

187

FENDER poltrona/armchair/fauteuil/Sessel
 • 1FENPA • 7139 Axinit platino, Cat.7 • piede/foot/pied/Fuß French Bronze
BABAR tavolino/small table/table/Couchtisch
 • 1BBRTROT • Dove Grey



188

189

FENDER poltrona/armchair/fauteuil/Sessel
 • 2FENPA • 9C1 Sensation Creta, Cat. H • piede/foot/pied/Fuß Gun Metal
JAGGER 75 tavolino/small table/table/Couchtisch ø 75
 • 1JAGTM • Bordeaux
BABAR tavolino/small table/table/Couchtisch
 • 1BBRTROT • Green

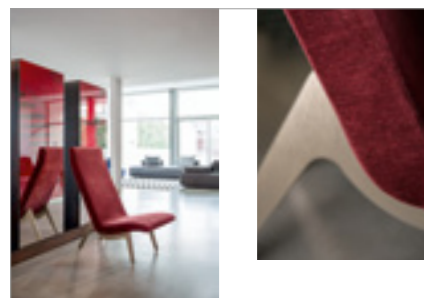

190

191

FENDER poltrona/armchair/fauteuil/Sessel
 • 1FENPA • 7164 Perseo Scarlatto, Cat. 7 • piede/foot/pied/Fuß French Bronze

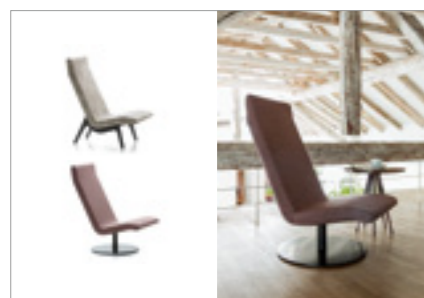

192

193

FENDER poltrona/armchair/fauteuil/Sessel
 • 2FENPA • 9C1 Sensation Creta, Cat. H • piede/foot/pied/Fuß Gun Metal
FENDER poltrona girevole/swivel armchair/fauteuil tournant/Drehsessel
 • 1FENPAG • 7143 Blenda Orchidea, Cat. 7 • basamento/base/piétement/Basis Gun Metal
JAGGER 50 tavolino/small table/table/Couchtisch ø 50
 • 1JAGTL • Bordeaux

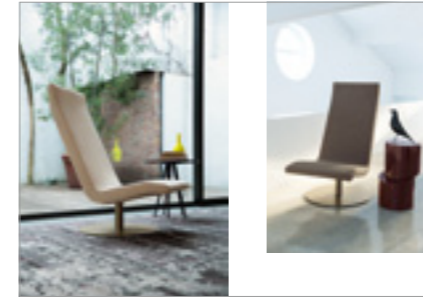
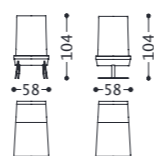

194

195

FENDER poltrona girevole/swivel armchair/fauteuil tournant/Drehsessel
 • 2FENPAG • 9G1 Nabuk Sabbia, Cat. I • basamento/base/piétement/Basis French Bronze
JAGGER 50 tavolino/small table/table/Couchtisch ø 50
 • 1JAGTL • Bordeaux
FENDER poltrona girevole/swivel armchair/fauteuil tournant/Drehsessel
 • 1FENPAG • 5339 Spirit terra, Cat. 5 • basamento/base/piétement/Basis French Bronze
BABAR tavolino/small table/table/Couchtisch
 • 1BBRTROT • Bordeaux

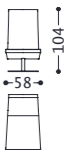

JAGGER



200 201

JAGGER 35 tavolino/small table/table/Couchtisch ø 35
 • 1JAGTH • Dove Grey
JAGGER 50 tavolino/small table/table/Couchtisch ø 50
 • 1JAGTL • Green
JAGGER 75 tavolino/small table/table/Couchtisch ø 75
 • 1JAGTM • Dove Grey

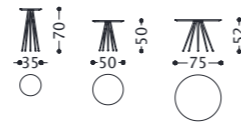

204 205

JAGGER 35 tavolino/small table/table/Couchtisch ø 35
 • 1JAGTH • Bordeaux
JAGGER 50 tavolino/small table/table/Couchtisch ø 50
 • 1JAGTL • Bordeaux
JAGGER 75 tavolino/small table/table/Couchtisch ø 75
 • 1JAGTM • Bordeaux

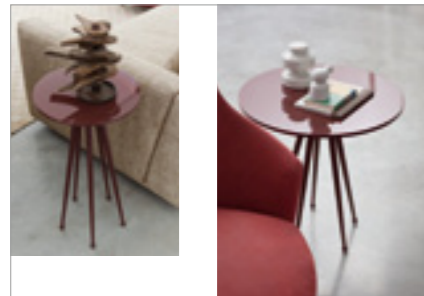
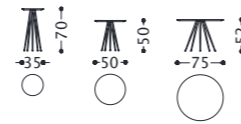

206 207

JAGGER 35 tavolino/small table/table/Couchtisch ø 35
 • 1JAGTH • Bordeaux
JAGGER 50 tavolino/small table/table/Couchtisch ø 50
 • 1JAGTL • Bordeaux

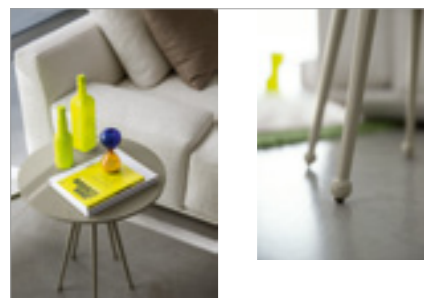
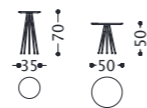

208 209

JAGGER 50 tavolino/small table/table/Couchtisch ø 50
 • 1JAGTL • Dove Grey



BABAR



210 211

BABAR tavolino/small table/table/Couchtisch
 • 1BBRTROT • Mink Brown
JAGGER 35 tavolino/small table/table/Couchtisch ø 35
 • 1JAGTH • Ivory



212 213

BABAR tavolino/small table/table/Couchtisch
 • 1BBRTROT • Mink brown
JAGGER 35 tavolino/small table/table/Couchtisch ø 35
 • 1JAGTH • Blue
JAGGER 50 tavolino/small table/table/Couchtisch ø 50
 • 1JAGTL • Bordeaux



214 215

BABAR tavolino/small table/table/Couchtisch
 • 1BBRTROT • Bordeaux
BABAR tavolino/small table/table/Couchtisch
 • 1BBRTROT • Blue
BABAR tavolino/small table/table/Couchtisch
 • 1BBRTROT • Yellow Fluo
BABAR tavolino/small table/table/Couchtisch
 • 1BBRTROT • Grey
BABAR tavolino/small table/table/Couchtisch
 • 1BBRTROT • Green

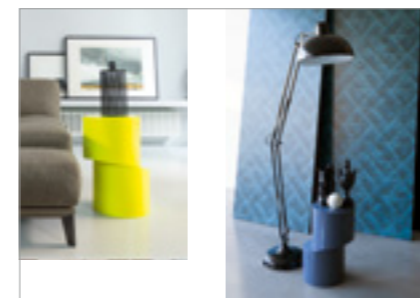

216 217

BABAR tavolino/small table/table/Couchtisch
 • 1BBRTROT • Yellow Fluo
BABAR tavolino/small table/table/Couchtisch
 • 1BBRTROT • Blue



218 219

BABAR tavolino/small table/table/Couchtisch
 • 1BBRTROT • Dove Grey



PHIL

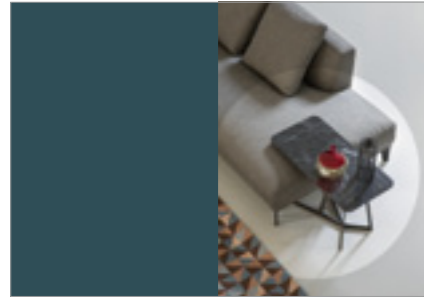

222 223

PHIL tavolino/small table/table/Couchtisch
 • 1PHISER • marmo/marble/marbre/Marmor Marquina Black, Cat. X2
 • struttura/structure/structure/Struktur Gun Metal

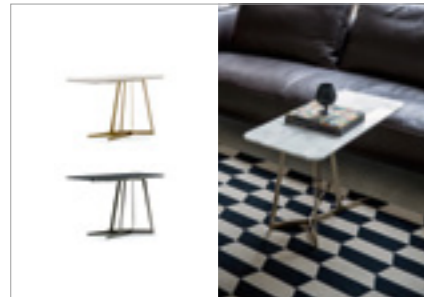

224 225

PHIL tavolino/small table/table/Couchtisch
 • 1PHISER • marmo/marble/marbre/Marmor Calacatta White, Cat. X4
 • struttura/structure/structure/Struktur French Bronze
 PHIL tavolino/small table/table/Couchtisch
 • 1PHISER • marmo/marble/marbre/Marmor Marquina Black, Cat. X2
 • struttura/structure/structure/Struktur Gun Metal

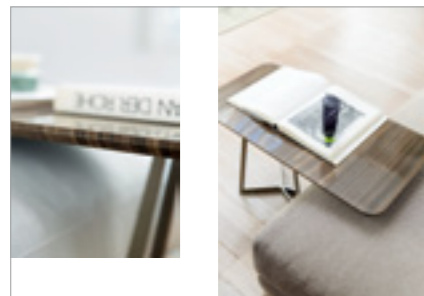

228 229

PHIL tavolino/small table/table/Couchtisch
 • 1PHISER • marmo/marble/marbre/Marmor Magic Brown, Cat. X1
 • struttura/structure/structure/Struktur French Bronze



230 231

PHIL tavolino/small table/table/Couchtisch
 • 1PHISERL • Bordeaux • struttura/structure/structure/Struktur French Bronze



232 233

PHIL tavolino/small table/table/Couchtisch
 • 1PHISERL • Mink Brown • struttura/structure/structure/Struktur Gun Metal



HUGO

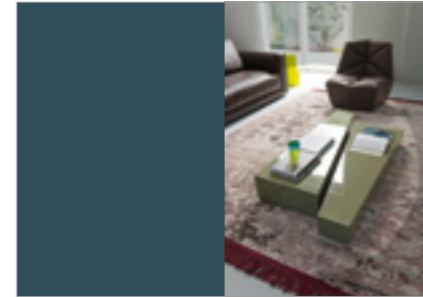

250 251

HUGO tavolino/small table/table/Couchtisch
 • 0HUGC1 (1HUGTH-1HUGTL) • Green

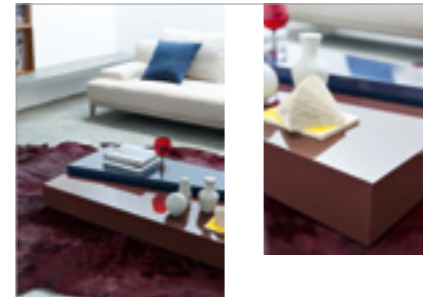
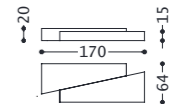

252 253

HUGO tavolino/small table/table/Couchtisch
 • 0HUGC1 (1HUGTH-1HUGTL) • Blue-Bordeaux



254 255

HUGO tavolino/small table/table/Couchtisch
 • 0HUGC1 (1HUGTH-1HUGTL) • Grey-Bordeaux

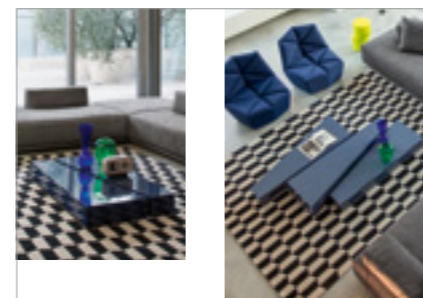
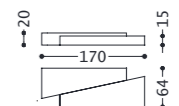
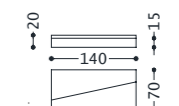

256 257

HUGO tavolino/small table/table/Couchtisch
 • 1HUGTH-1HUGTH • Blue
 HUGO tavolino/small table/table/Couchtisch
 • 0HUGC1 (1HUGTH-1HUGTL)-1HUGTH • Blue

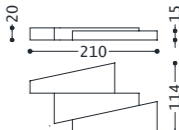

258 259

HUGO tavolino/small table/table/Couchtisch
 • 0HUGC1 (1HUGTH-1HUGTL) • Grey

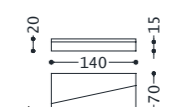

FRISCO



234

FRISCO 50 tavolino/small table/table/Couchtisch ø 50
 • 1FRITROT • Top 1 marmo/marble/marbre/Marmor Marquina Black, Cat. X2 • Top 2 Grey • struttura/structure/structure/Struktur Gun Metal

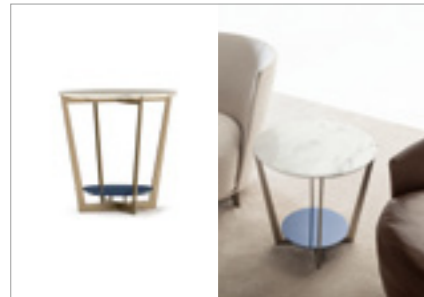

236

FRISCO 50 tavolino/small table/table/Couchtisch ø 50
 • 1FRITROT • Top 1 marmo/marble/marbre/Marmor Calacatta White, Cat. X4 • Top 2 Blue • struttura/structure/structure/Struktur French Bronze

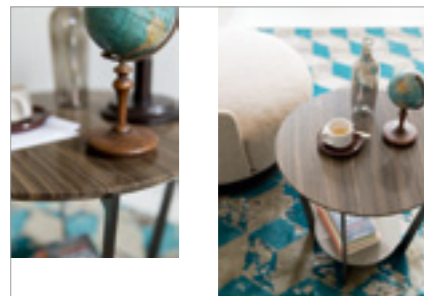

238

FRISCO 50 tavolino/small table/table/Couchtisch ø 50
 • 1FRITROT • Top 1 marmo/marble/marbre/Marmor Magic Brown, Cat. X1 • Top 2 Dove Grey • struttura/structure/structure/Struktur Gun Metal

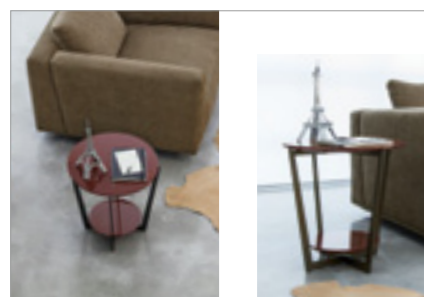

240

FRISCO 50 tavolino/small table/table/Couchtisch ø 50
 • 1FRITROTL • Top 1 Bordeaux • Top 2 Bordeaux • struttura/structure/structure/structure/Struktur Gun Metal

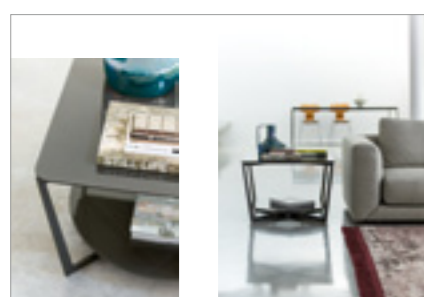

242

FRISCO 75 tavolino/small table/table/Couchtisch 75x75
 • 1FRITVQAL • Top 1 Mink Brown • Top 2 Mink Brown • struttura/structure/structure/Struktur Gun Metal



244

FRISCO 75 tavolino/small table/table/Couchtisch 75x75
 • 1FRITAVQA • Top 1 marmo/marble/marbre/Marmor Calacatta White, Cat. X4 • Top 2 Bordeaux • struttura/structure/structure/Struktur Gun Metal

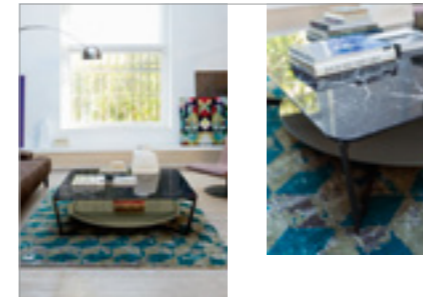

246

FRISCO 120 tavolino/small table/table/Couchtisch 120x120
 • 1FRITAVQB • Top 1 marmo/marble/marbre/Marmor Calacatta White, Cat. X4 • Top 2 Green • struttura/structure/structure/Struktur French Bronze



248

FRISCO 75 tavolino/small table/table/Couchtisch 75x75
 • 1FRITAVQA • Top 1 marmo/marble/marbre/Marmor Calacatta White, Cat. X4 • Top 2 Green • struttura/structure/structure/Struktur Gun Metal



FRISCO 120 tavolino/small table/table/Couchtisch 120x120
 • 1FRITAVQB • Top 1 marmo/marble/marbre/Marmor Marquina Black, Cat. X2 • Top 2 Green • struttura/structure/structure/Struktur Gun Metal

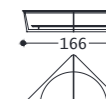

MORRISON pouff/pouf/pouf/Hocker
 • 1MOR191 • 7142 Axinit Corda, Cat. 7

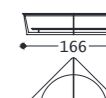

FRISCO 120 tavolino/small table/table/Couchtisch 120x120
 • 1FRITAVQB • Top 1 marmo/marble/marbre/Marmor Calacatta White, Cat. X4 • Top 2 Green • struttura/structure/structure/Struktur French Bronze



JAGGER 50 tavolino/small table/table/Couchtisch ø 50
 • 1JAGTL Blue

PHIL tavolino/small table/table/Couchtisch
 • 1PHISER • marmo/marble/marbre/Marmor Calacatta White, Cat. X4
 • struttura/structure/structure/Struktur French Bronze

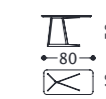

AREA PROGETTO.
PROJECT AREA



AREA 1

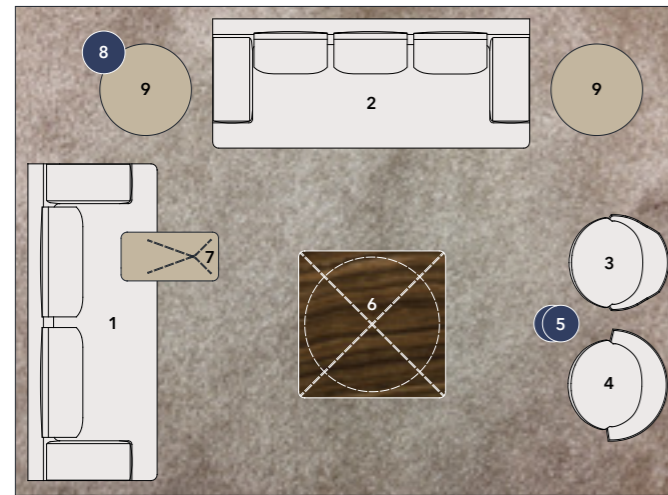

22 m²

DIVANI·SOFAS

- 1 RONNY divano/sofa/canapé/Sofa
cm 260x106 • 1RNN230
- 2 MORRISON divano/sofa/canapé/Sofa
cm 260x106 • 1MOR130

POLTRONE·ARMCHAIRS

- 3 JAMMIN poltrona/armchair/fauteuil/Sessel
cm 83x83 h 76 • 1JAMP
- 4 JAMMIN LARGE poltrona/armchair/fauteuil/Sessel
cm 95x83 h 76 • 1JAMPL

TAVOLINI·SMALL TABLES

- 5 BABAR tavolino/small table/table/Couchtish
ø cm 37 h 52 • 1BBRTROT
- 6 FRISCO tavolino/small table/table/Couchtish
cm 120x120 h 35 • 1FRITAVQB
- 7 PHIL tavolino/small table/table/Couchtish
cm 80x40 h 50 • 1PHISER
- 8 JAGGER tavolino/small table/table/Couchtish
ø cm 35 h 70 • 1JAGTH
- 9 JAGGER tavolino/small table/table/Couchtish
ø cm 75 h 52 • 1JAGTM

AREA 3

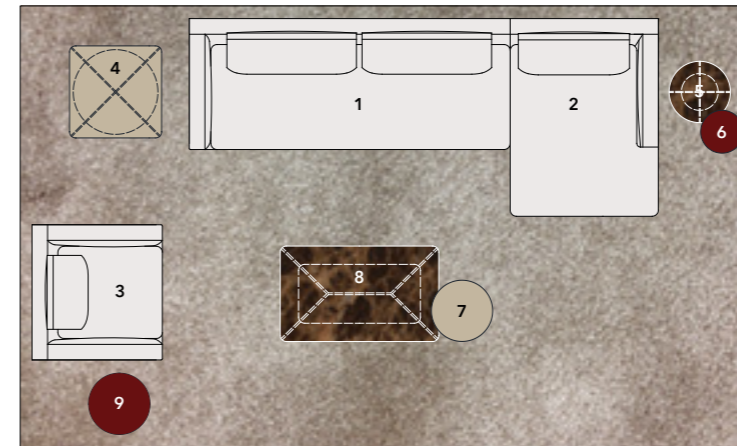

22 m²

DIVANO·SOFA

composizione/composition/composition/Komposition
01BOWC6 (1BOW210SX + 1BOW280DX)

- 1 BOWIE divano sinistro/sofa with left arm/
batard gauche/Sofa armlehne links
cm 200x106 • 1BOW210SX
- 2 BOWIE chaise longue destra/chaise longue with right arm/
chaise longue droite/Liege armlehne rechts
cm 120x160 • 1BOW280DX
- 3 BOWIE poltrona/armchair/fauteuil/Sessel
cm 110x106 • 1BOW310

TAVOLINI·SMALL TABLES

- 4 FRISCO tavolino/small table/table/Couchtish
cm 75x75 h 50 • 1FRITAVQA
- 5 JAGGER tavolino/small table/table/Couchtish
ø cm 75 h 52 • 1JAGTM
- 6 JAGGER tavolino/small table/table/Couchtish
ø cm 35 h 70 • 1JAGTH
- 7 JAGGER tavolino/small table/table/Couchtish
ø cm 50 h 50 • 1JAGTL
- 8 FRISCO tavolino/small table/table/Couchtish
cm 130x78 h 35 • 1FRITAVR
- 9 FRISCO tavolino/small table/table/Couchtish
ø cm 50 h 50 • 1FRITROT

AREA 2

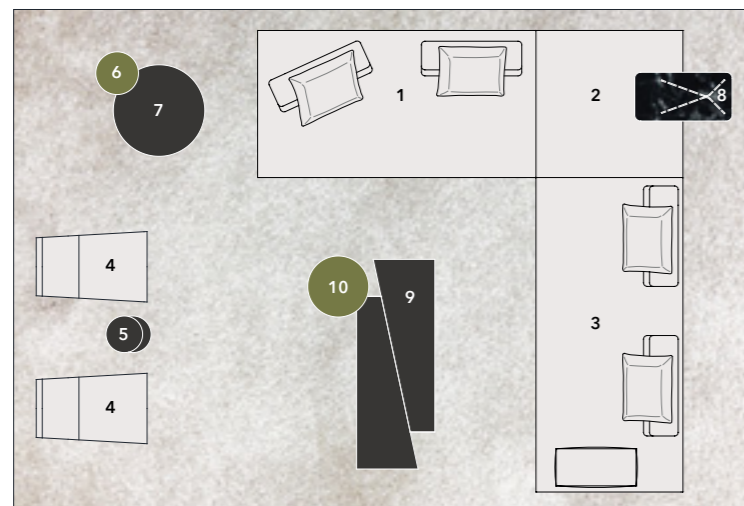

24 m²

DIVANO·SOFA

composizione/composition/composition/Komposition
01YK1C4 (1YK1421 + 1YK1431 + 1YK1411)

- 1 YOKO 1 seduta/seat/assise/Sitz
cm 263x123 • 1YK1421
- 2 YOKO 1 pouff/pouf/pouf/Hocker
cm 123x123 • 1YK1431
- 3 YOKO 1 seduta/seat/assise/Sitz
cm 233x123 • 1YK1411

POLTRONE·ARMCHAIRS

- 4 FENDER poltrona/armchair/fauteuil/Sessel
cm 58x92 h 104 • 1FENPA

TAVOLINI·SMALL TABLES

- 5 BABAR tavolino/small table/table/Couchtish
ø cm 37 h 52 • 1BBRTROT
- 6 JAGGER tavolino/small table/table/Couchtish
ø cm 35 h 70 • 1JAGTH
- 7 JAGGER tavolino/small table/table/Couchtish
ø cm 75 h 52 • 1JAGTM
- 8 PHIL tavolino/small table/table/Couchtish
cm 80x40 h 50 • 1PHISER
- 9 HUGO tavolino/small table/table/Couchtish
cm 170x64 h 20 • 0HUGC1
- 10 JAGGER tavolino/small table/table/Couchtish
ø cm 50 h 50 • 1JAGTL

AREA 4

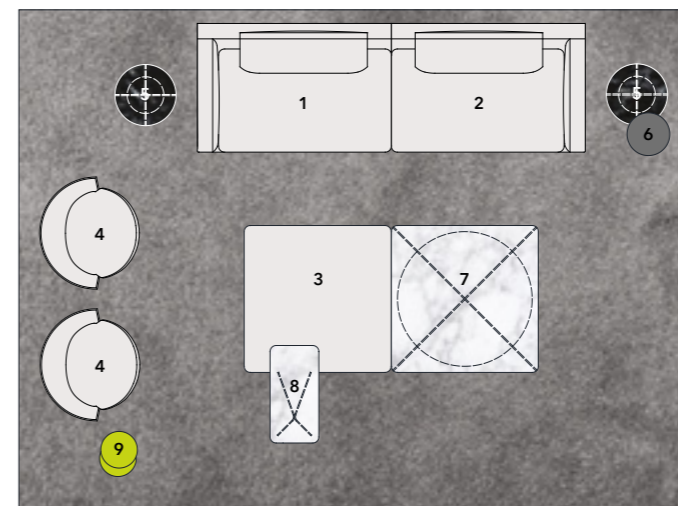

23 m²

DIVANO·SOFA

composizione/composition/composition/Komposition
01CINC4 (1CIN100SX + 1CIN100DX)

- 1 CINDY divano sinistro/sofa with left arm/
batard gauche/Sofa armlehne links
cm 160x106 • 1CIN100SX
- 2 CINDY destro/sofa with right arm/batard droit/
Sofa armlehne rechts
cm 160x106 • 1CIN100DX
- 3 CINDY pouff/pouf/pouf/Hocker
cm 120x120 • 1CIN191

POLTRONE·ARMCHAIRS

- 4 JAMMIN LARGE poltrona/armchair/fauteuil/Sessel
cm 95x83 h 76 • 1JAMPL

TAVOLINI·SMALL TABLES

- 5 FRISCO tavolino/small table/table/Couchtish
ø cm 50 h 50 • 1FRITROT
- 6 JAGGER tavolino/small table/table/Couchtish
ø cm 35 h 70 • 1JAGTH
- 7 FRISCO tavolino/small table/table/Couchtish
cm 120x120 h 35 • 1FRITAVQB
- 8 PHIL tavolino/small table/table/Couchtish
cm 80x40 h 50 • 1PHISER
- 9 BABAR tavolino/small table/table/Couchtish
ø cm 37 h 52 • 1BBRTROT

FINITURE • FINISHING



MARMO/MARBLE/MARBRE/MARMOR



Magic Brown • Cat. X1

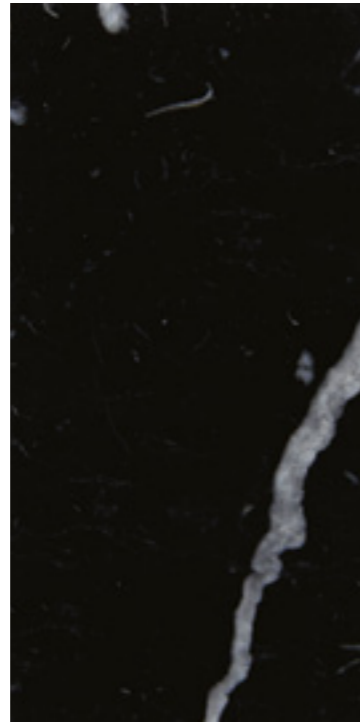

Marquina Black • Cat. X2



Daino Reale • Cat. X2

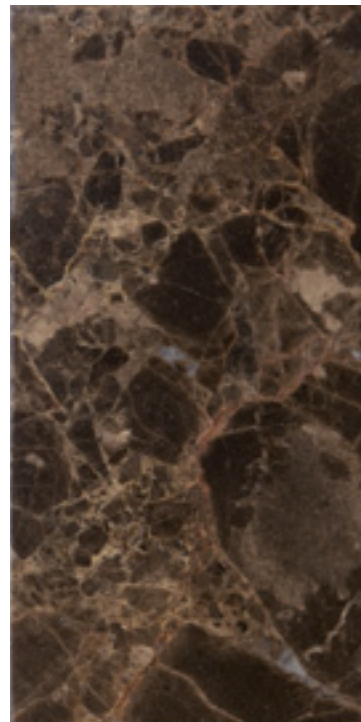

Emperador Brown • Cat. X3



Onice Rosso • Cat. X4



Calacatta White • Cat. X4

METALLO/METAL/MÉTAL/METALL



Gun Metal



French Bronze

LACCATI/LACQUERED/LAQUÉS/LACKIERT

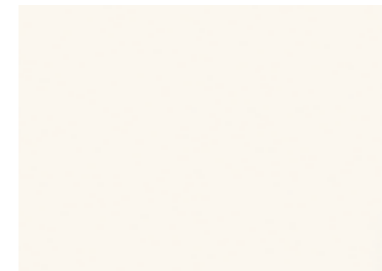

Ivory

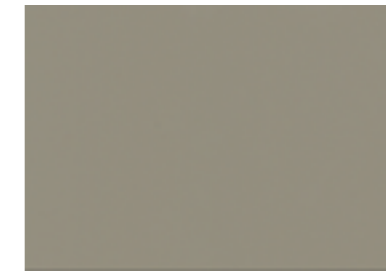

Grey



Dove Grey

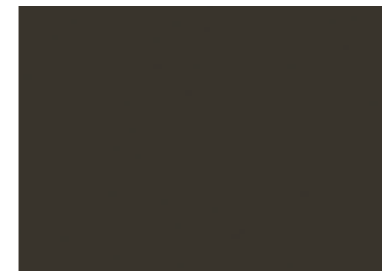

Mink Brown

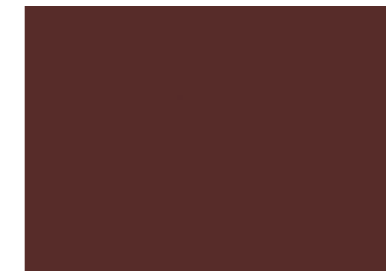

Bordeaux



Rust



Green



Blue



Yellow Fluo

DATI TECNICI • TECHNICAL DATA

DIVANI • SOFAS

FLOYD • FLOYD 120 DEEP	292
DYLAN	296
BOWIE	298
CINDY	300
RONNY	302
MORRISON	304
BRUCE	306
YOKO 1	308
YOKO 2	309

POLTRONE • ARMCHAIRS

GOSSIP	310
JAMMIN • JAMMIN LARGE	312
FENDER	311

TAVOLINI • SMALL TABLES

JAGGER	313
BABAR	313
PHIL	314
FRISCO	315
HUGO	314

FLOYD • FLOYD 120 DEEP divano/sofa/canapé/sofa
 elementi/elements/éléments/elemente



Struttura portante: Multistrato, legno massello.
Imbottiture: Schienale in piuma d'oca. Seduta in piuma d'oca con inserto in poliuretano espanso a densità differenziata (35-30 Kg/mc). Scocca in poliuretano espanso a densità differenziata rivestito in resinato 100 g accoppiato con vellutino.
Molle: Cinghie elastiche in polipropilene e gomma.

Main structure: Solid wood.
Upholstery: Backrest in goose feathers. Seat in goose feathers with internal padding in polyurethane foam with different densities (35-30 Kg/mc). Chassis in polyurethane foam with different densities covered with resinate 100 g and elastic velvet.
Suspensions: Elastic belts in polypropylene and rubber.

Structure: Multiplis et bois massif.
Rembourrage: Dossier en plume d'oie. Assise en plume d'oie avec insert en mousse de polyuréthane en plusieurs densités (35-30 Kg/mc). Chassis en mousse de polyuréthane avec plusieurs densités recouvert avec resiné 100 g couplé avec velour.
Suspension: Sangles élastiques en polypropylène et mousse.

Struktur: Vielschichtiges Massivholz.
Polsterung: Rückenlehne aus Gänsedaunen. Sitz aus Gänsedaunen mit Einsatz aus Polyurethanschaum in unterschiedlichen Dichten (35-30 Kg/mc). Chassis aus Polyurethanschaum in unterschiedlichen Dichten beschichtet mit Resinat 100 g Samt gekoppeltem.
Federung: Elastische Gurte aus Gummi und Polypropylen.

Cod. Tessuto/fabric/tissu/Stoff: 01/1
 Cod. Pelle/leather/cuir/Leder: 02/2

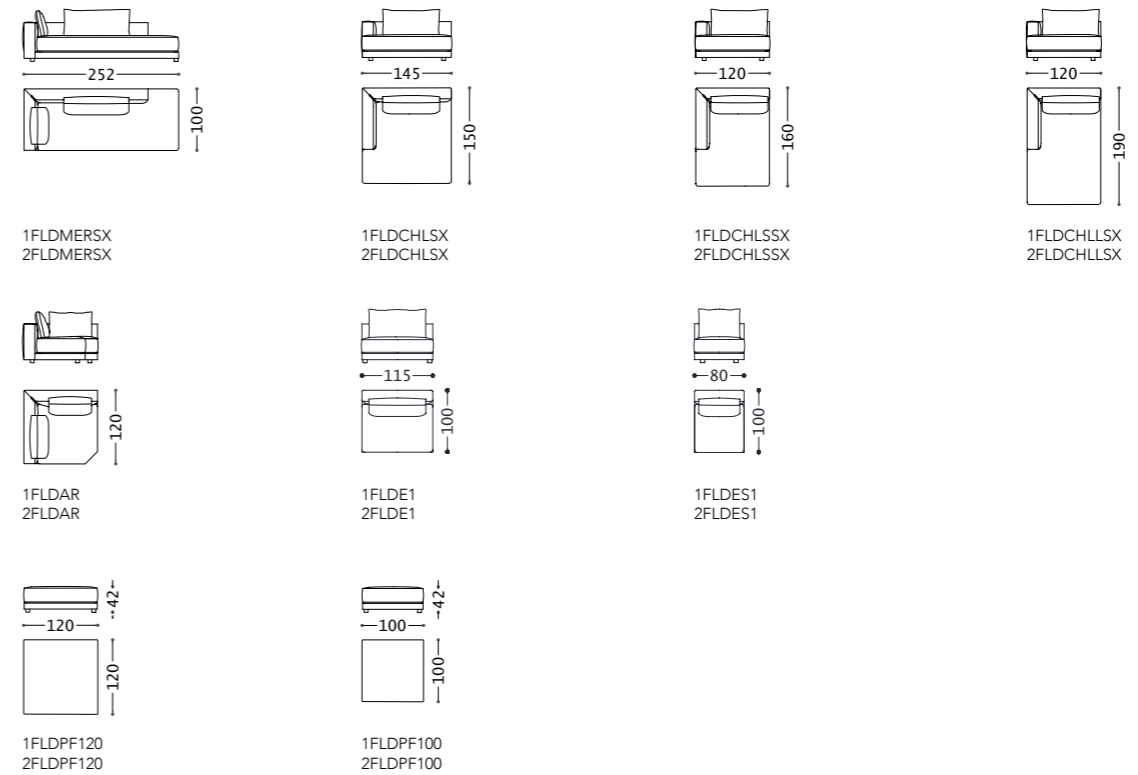
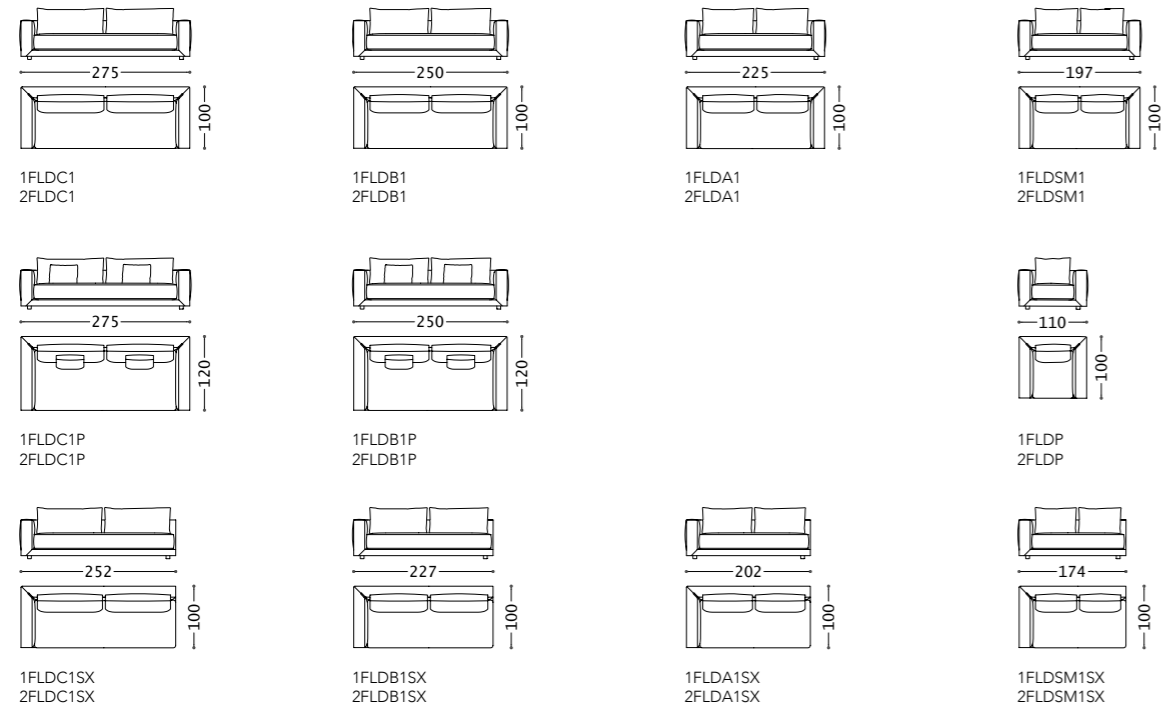
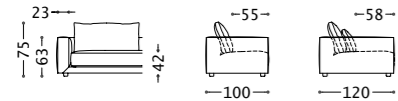

FLOYD • FLOYD 120 DEEP divano/sofa/canapé/sofa
 composizioni/compositions/compositions/Kompositionen

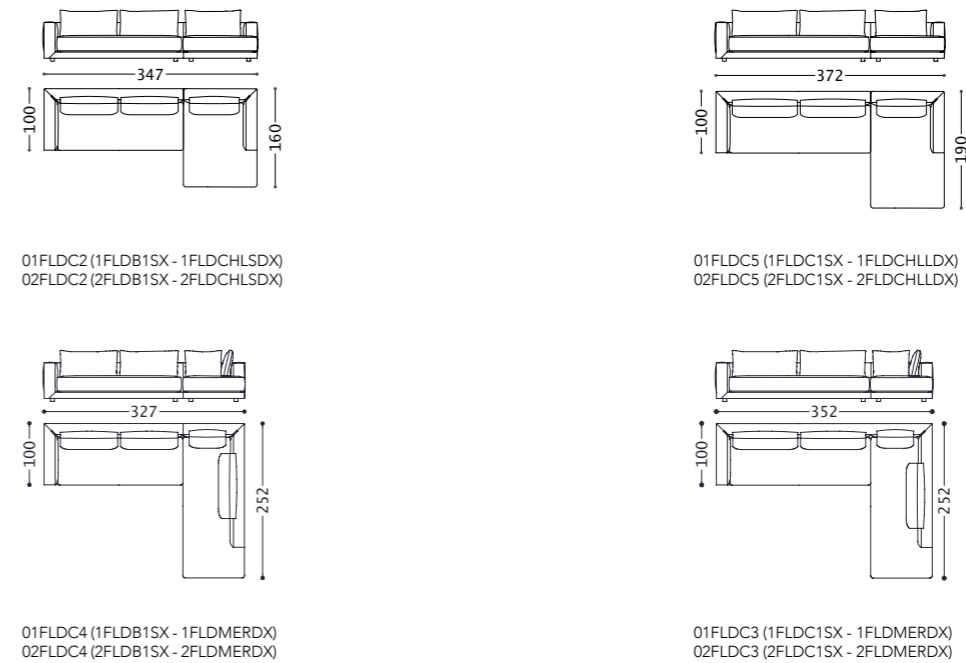

FLOYD • FLOYD 120 DEEP

divano/sofa/canapé/sofa

elementi con tavolino/elements with small table/éléments avec table/Elemente mit Couchtisch

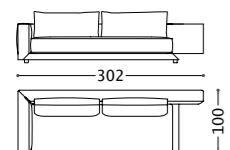

1FLDESPSX
2FLDESPSX

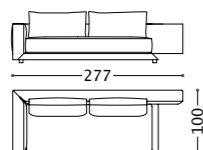

1FLDESPMSX
2FLDESPMSX

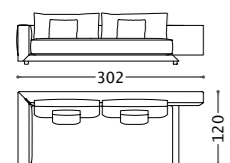

1FLDESPPRSX
2FLDESPPRSX

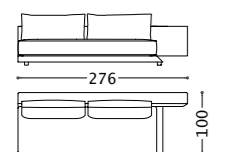

1FLDESP1TDX
2FLDESP1TDX

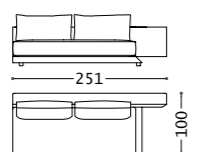

1FLDESPSM1TDX
2FLDESPSM1TDX

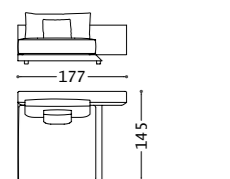

1FLDCHLC1TDX
2FLDCHLC1TDX

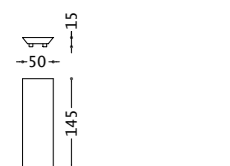

1FLTTAVCM
1FLTTAVCML

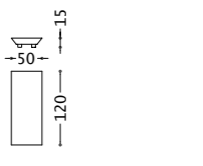

1FLTTAVTP
1FLTTAVTPL

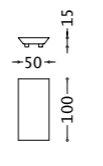

1FLTTAVTS
1FLTTAVTSL

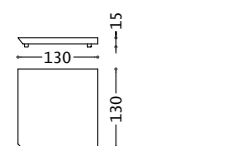

1FLTTAVAPDXSX
1FLTTAVAPDXSXL

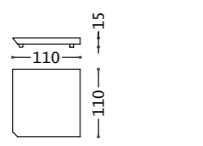

1FLTTAVADXSX
1FLTTAVADXSXL

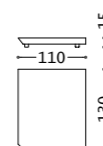

1FLTTAVAPDX*
1FLTTAVAPDXL*

FLOYD • FLOYD 120 DEEP

divano/sofa/canapé/sofa

composizioni con tavolino/compositions with small table/compositions avec table/Kompositionen mit Couchtisch

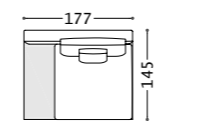

1FLTTAVCM + 1FLDCHLC1TSX
1FLTTAVCM + 2FLDCHLC1TSX
1FLTTAVCML + 1FLDCHLC1TSX
1FLTTAVCML + 2FLDCHLC1TSX

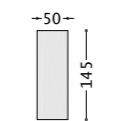

1FLTTAVCM
1FLTTAVCML

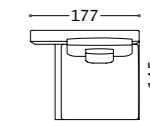

1FLDCHLC1TSX
2FLDCHLC1TSX

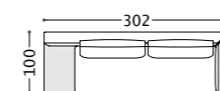

1FLTTAVTS + 1FLDESPPDX
1FLTTAVTS + 2FLDESPPDX
1FLTTAVTSL + 1FLDESPPDX
1FLTTAVTSL + 2FLDESPPDX

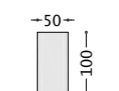

1FLTTAVTS
1FLTTAVTSL

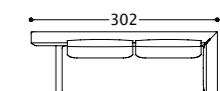

1FLDESPPDX
2FLDESPPDX

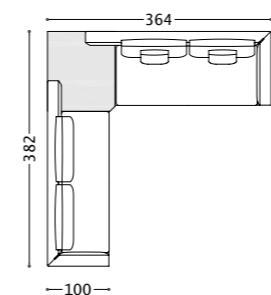

1FLDESPPSX - 1FLTTAVAPSX - 1FLDESPPDX
2FLDESPPSX - 1FLTTAVAPSX - 2FLDESPPDX
1FLDESPPSX - 1FLTTAVAPXSL - 1FLDESPPDX
2FLDESPPSX - 1FLTTAVAPXSL - 2FLDESPPDX

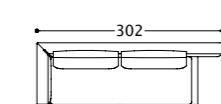

1FLDESPPSX
2FLDESPPSX

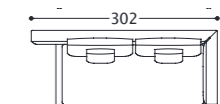

1FLDESPPDX
2FLDESPPDX

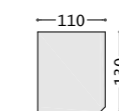

1FLTTAVAPSX
1FLTTAVAPXSL

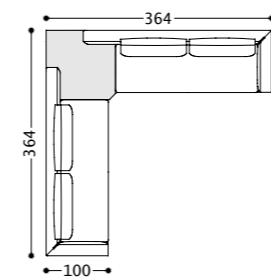

1FLDESPPSX - 1FLTTAVADXSX - 1FLDESPPDX
2FLDESPPSX - 1FLTTAVADXSX - 2FLDESPPDX
1FLDESPPSX - 1FLTTAVADXSXL - 1FLDESPPDX
2FLDESPPSX - 1FLTTAVADXSXL - 2FLDESPPDX

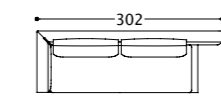

1FLDESPPSX
2FLDESPPSX

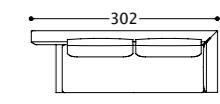

1FLDESPPDX
2FLDESPPDX

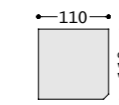

1FLTTAVADXSX
1FLTTAVADXSXL

*Il verso del tavolo destro e sinistro a profondità differenziata viene determinato dal lato nel quale si aggiunge l'elemento a profondità standard (100cm)
The right/left orientation of the small table with a different depth is determined by the side on which the standard element (d.100 cms) hangs up.



Struttura portante: Multistrato, massello di legno.
Imbottiture: Schienale in piuma d'oca. Seduta in piuma d'oca con inserto in poliuretano espanso (densità 30 Kg/mc). Bracciolo in piuma d'oca con inserto in poliuretano espanso a densità differenziata (40-25 Kg/mc).
Molleggio: Cinghie elastiche in polipropilene e gomma.
Piedino: In metallo (opzioni finitura: French Bronze o Gun Metal).

Main structure: Solid wood.
Upholstery: Backrest in goose feathers. Seat in goose feathers with internal padding in polyurethane foam (density 30 Kg/mc). Armrest in goose feathers with internal padding in polyurethane foam with different densities (40 - 25 Kg/mc).
Suspensions: Elastic belts in polypropylen and rubber.
Feet: In metal (finishing options: French Bronze or Gun Metal).

Structure: Multiplis et bois massif.
Rembourrage: Dossier en plume d'oie. Assise en plume d'oie avec insert en mousse de polyuréthane (densité 30 Kg/mc). Accoudoir en plume d'oie avec insert en mousse de polyuréthane avec plusieurs densités (40 - 25 Kg/mc).
Suspension: Sangles élastiques en polypropylène et mousse.
Feet: En metal (versions de finitions: French Bronze ou Gun Metal).

Struktur: Vielschichtiges Massivholz.
Polsterung: Rückenlehne aus Gänsedaunen. Sitz aus Gänsedaunen mit Einsatz aus Polyurethanschaum (Dichte 30 Kg/mc). Armlehne aus Gänsedaunen mit Einsatz aus Polyurethanschaum in unterschiedlichen Dichten (40 - 25 Kg/mc).
Federung: Elastische Gurte aus Gummi und Polypropylen.
Füße: Aus Metall (Auswahl: French Bronze oder Gun Metal).

Cod. Tessuto/fabric/tissu/Stoff: 01/1
Cod. Pelle/leather/cuir/Leder: 02/2

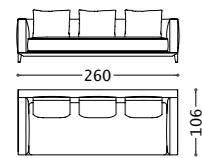
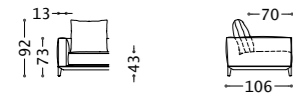

1DYL230
2DYL230

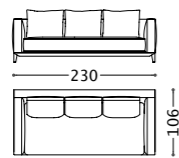

1DYL220
2DYL220

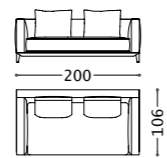

1DYL210
2DYL210

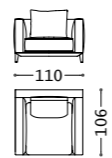

1DYL310
2DYL310

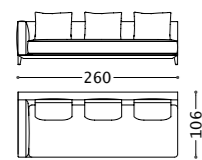

1DYL230SX
2DYL230SX

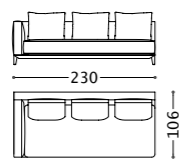

1DYL220SX
2DYL220SX

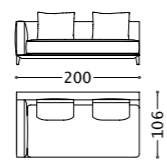

1DYL210SX
2DYL210SX

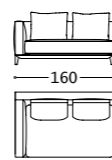

1DYL200SX
2DYL200SX

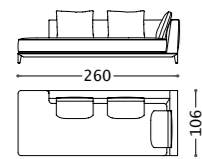

1DYL270SX
2DYL270SX

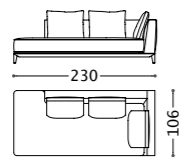

1DYL260SX
2DYL260SX

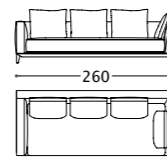

1DYL271SX
2DYL271SX



1DYL261SX
2DYL261SX

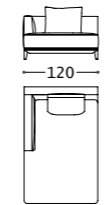

1DYL281SX
2DYL281SX

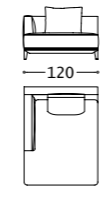

1DYL280SX
2DYL280SX

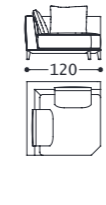

1DYL300
2DYL300

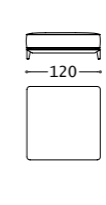

1DYL290
2DYL290

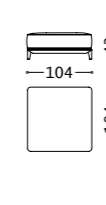

1DYL291
2DYL291

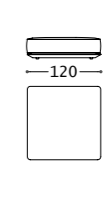

1DYL191
2DYL191

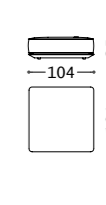

1DYL192
2DYL192

DYLAN divano/sofa/canapé/sofa
composizioni/compositions/compositions/Kompositionen

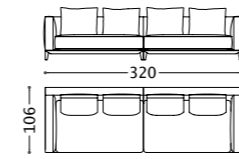

01DYLC4
(1DYL200SX + 1DYL200DX)
02DYLC4
(2DYL200SX + 2DYL200DX)

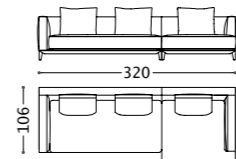

01DYLC3
(1DYL210SX + 1DYL280DX)
02DYLC3
(2DYL210SX + 2DYL280DX)

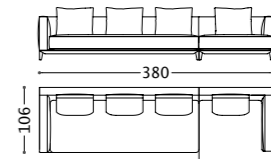

01DYLC6
(1DYL230SX + 1DYL280DX)
02DYLC6
(2DYL230SX + 2DYL280DX)

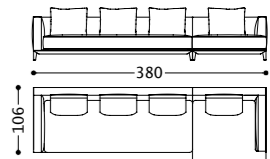

01DYLC10
(1DYL230SX + 1DYL281DX)
02DYLC6
(2DYL230SX + 2DYL281DX)

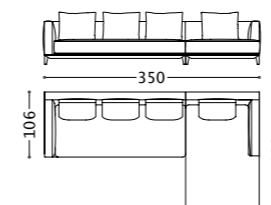

01DYLC8
(1DYL220SX + 1DYL281DX)
02DYLC8
(2DYL220SX + 2DYL281DX)

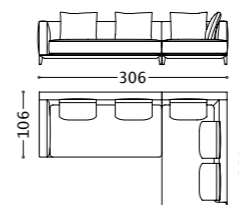

01DYLC2
(1DYL210SX + 1DYL260DX)
02DYLC2
(2DYL210SX + 2DYL260DX)

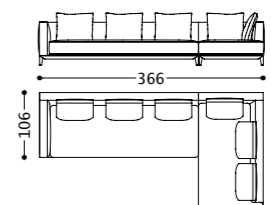

01DYLC11
(1DYL230SX + 1DYL260DX)
02DYLC11
(2DYL230SX + 2DYL260DX)

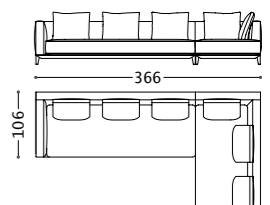

01DYLC1
(1DYL230SX + 1DYL270DX)
02DYLC1
(2DYL230SX + 2DYL270DX)

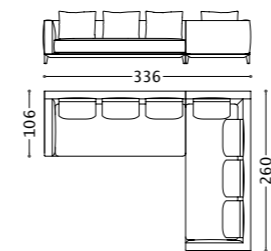

01DYLC5
(1DYL220SX + 1DYL271DX)
02DYLC5
(2DYL220SX + 2DYL271DX)

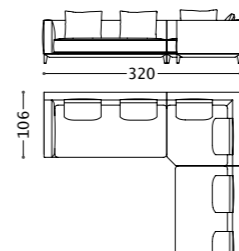

01DYLC9
(1DYL210SX + 1DYL300 + 1DYL210DX)
02DYLC9
(2DYL210SX + 2DYL300 + 2DYL210DX)

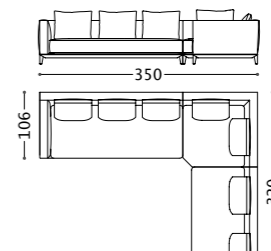

01DYLC7
(1DYL220SX + 1DYL300 + 1DYL210DX)
02DYLC7
(2DYL220SX + 2DYL300 + 2DYL210DX)

BOWIE divano/sofa/canapé/sofa
elementi/elements/éléments/elemente



Struttura portante: Multistrato, massello di legno.
Imbottiture: Schienale in piuma d'oca. Seduta in piuma d'oca con inserto in poliuretano espanso (densità 30 Kg/mc). Bracciolo in piuma d'oca con inserto in poliuretano espanso a densità differenziata (40-25 Kg/mc).
Molleggio: Cinghie elastiche in polipropilene e gomma.
Piedino: In metallo (opzioni finitura: French Bronze o Gun Metal).

Main structure: Solid wood.
Upholstery: Backrest in goose feathers. Seat in goose feathers with internal padding in polyurethane foam (density 30 Kg/mc). Armrest in goose feathers with internal padding in polyurethane foam with different densities (40 - 25 Kg/mc).
Suspensions: Elastic belts in polypropylen and rubber.
Feet: In metal (finishing options: French Bronze or Gun Metal).

Structure: Multiplis et bois massif.
Rembourrage: Dossier en plume d'oie. Assise en plume d'oie avec insert en mousse de polyuréthane (densité 30 Kg/mc). Accoudoir en plume d'oie avec insert en mousse de polyuréthane avec plusieurs densités (40 - 25 Kg/mc).
Suspension: Sangles élastiques en polypropylène et mousse.
Feet: En metal (versions de finitions: French Bronze ou Gun Metal).

Struktur: Vielschichtiges Massivholz.
Polsterung: Rückenlehne aus Gänsedaunen. Sitz aus Gänsedaunen mit Einsatz aus Polyurethanschaum (Dichte 30 Kg/mc). Armlehne aus Gänsedaunen mit Einsatz aus Polyurethanschaum in unterschiedlichen Dichten (40 - 25 Kg/mc).
Federung: Elastische Gurte aus Gummi und Polypropylen.
Füße: Aus Metall (Auswahl: French Bronze oder Gun Metal).

Cod. Tessuto/fabric/tissu/Stoff: 01/1
Cod. Pelle/leather/cuir/Leder: 02/2

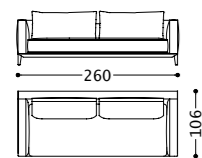
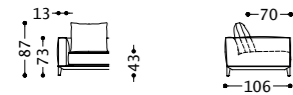

1BOW230
2BOW230

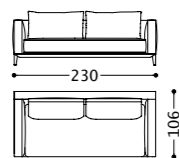

1BOW220
2BOW220

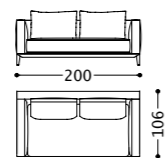

1BOW210
2BOW210

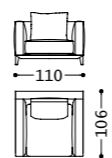

1BOW310
2BOW310

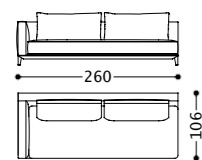

1BOW230SX
2BOW230SX

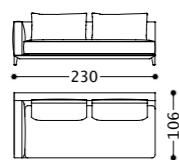

1BOW220SX
2BOW220SX

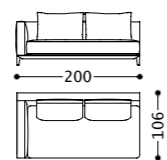

1BOW210SX
2BOW210SX

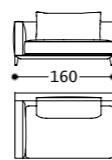

1BOW200SX
2BOW200SX

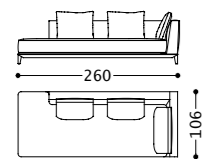

1BOW270SX
2BOW270SX

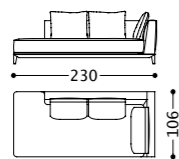

1BOW260SX
2BOW260SX

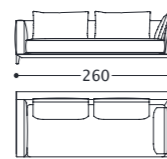

1BOW271SX
2BOW271SX



1BOW261SX
2BOW261SX

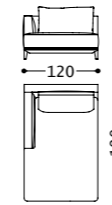

1BOW281SX
2BOW281SX

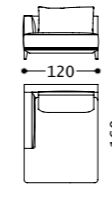

1BOW280SX
2BOW280SX

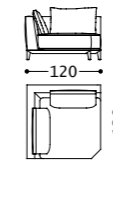

1BOW300
2BOW300

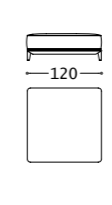

1BOW290
2BOW290

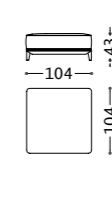

1BOW291
2BOW291

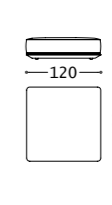

1BOW191
2BOW191

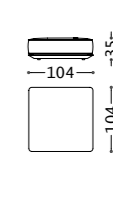

1BOW192
2BOW192

BOWIE divano/sofa/canapé/sofa
composizioni/compositions/compositions/Kompositionen

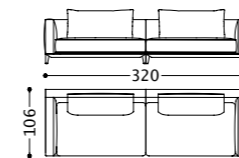

01BOWC4
(1BOW200SX + 1BOW200DX)
02BOWC4
(2BOW200SX + 2BOW200DX)

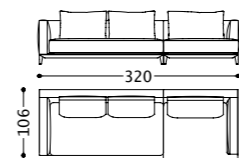

01BOWC3
(1BOW210SX + 1BOW280DX)
02BOWC3
(2BOW210SX + 2BOW280DX)

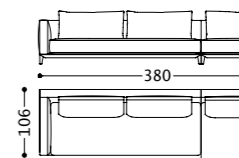

01BOWC6
(1BOW230SX + 1BOW280DX)
02BOWC6
(2BOW230SX + 2BOW280DX)

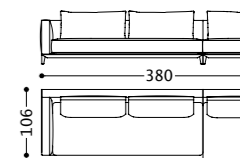

01BOWC10
(1BOW230SX + 1BOW281DX)
02BOWC10
(2BOW230SX + 2BOW281DX)

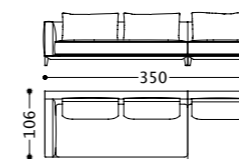

01BOWC8
(1BOW220SX + 1BOW281DX)
02BOWC8
(2BOW220SX + 2BOW281DX)

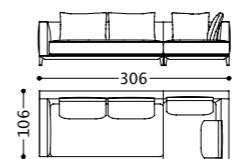

01BOWC2
(1BOW210SX + 1BOW260DX)
02BOWC2
(2BOW210SX + 2BOW260DX)

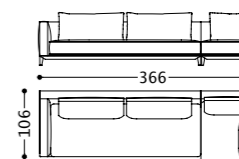

01BOWC11
(1BOW230SX + 1BOW260DX)
02BOWC11
(2BOW230SX + 2BOW260DX)

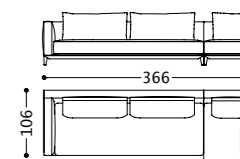

01BOWC1
(1BOW230SX + 1BOW270DX)
02BOWC1
(2BOW230SX + 2BOW270DX)

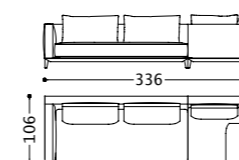

01BOWC5
(1BOW220SX + 1BOW271DX)
02BOWC5
(2BOW220SX + 2BOW271DX)

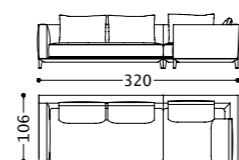

01BOWC9
(1BOW210SX + 1BOW300 + 1BOW210DX)
02BOWC9
(2BOW210SX + 2BOW300 + 2BOW210DX)

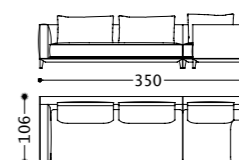

01BOWC7
(1BOW220SX + 1BOW300 + 1BOW210DX)
02BOWC7
(2BOW220SX + 2BOW300 + 2BOW210DX)

CINDY divano/sofa/canapé/sofa
elementi/elements/éléments/elemente



Struttura portante: Multistrato, massello di legno.
Imbottiture: Schienale in piuma d'oca. Seduta in piuma d'oca con inserto in poliuretano espanso a densità differenziata (30-25 Kg/mc). Bracciolo in piuma d'oca con inserto in poliuretano espanso a densità differenziata (40-25 Kg/mc).
Molle: Cinghie elastiche in polipropilene e gomma.
Piedino: In ABS.

Main structure: Solid wood.
Upholstery: Backrest in goose feathers. Seat in goose feathers with internal padding in polyurethane foam with different densities (30-25 Kg/mc). Armrest in goose feathers with internal padding in polyurethane foam with different densities (40 - 25 Kg/mc).
Suspensions: Elastic belts in polypropylen and rubber.
Feet: In ABS.

Structure: Multiplis et bois massif.
Rembourrage: Dossier en plume d'oie. Assise en plume d'oie avec insert en mousse de polyuréthane avec plusieurs densités (30-25 Kg/mc). Accoudoir en plume d'oie avec insert en mousse de polyuréthane avec plusieurs densités (40 - 25 Kg/mc).
Suspension: Sangles élastiques en polypropylène et mousse.
Feet: En ABS.

Struktur: Vielschichtiges Massivholz.
Polsterung: Rückenlehne aus Gänsedaunen. Sitz aus Gänsedaunen mit Einsatz aus Polyurethanschaum in unterschiedlichen Dichten (30-25 Kg/mc). Armlehne aus Gänsedaunen mit Einsatz aus Polyurethanschaum in unterschiedlichen Dichten (40 - 25 Kg/mc).
Federung: Elastische Gurte aus Gummi und Polypropylen.
FüÙe: ABS.

Cod. Tessuto/fabric/tissu/Stoff: 01/1
Cod. Pelle/leather/cuir/Leder: 02/2

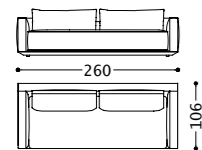
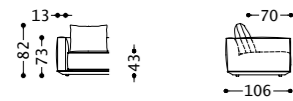

1CIN130
2CIN130

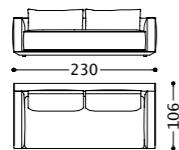

1CIN120
2CIN120

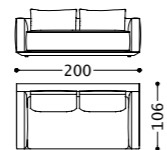

1CIN110
2CIN110

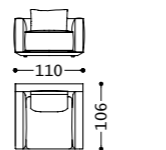

1CIN310
2CIN310

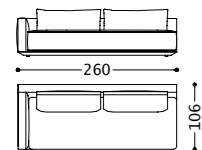

1CIN130SX
2CIN130SX

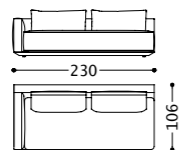

1CIN120SX
2CIN120SX

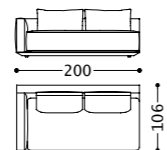

1CIN110SX
2CIN110SX

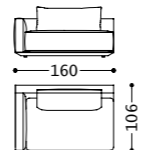

1CIN100SX
2CIN100SX

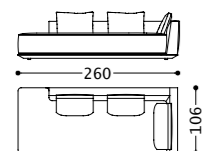

1CIN170SX
2CIN170SX

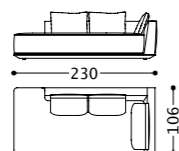

1CIN160SX
2CIN160SX

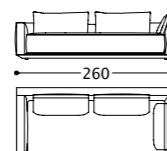

1CIN171SX
2CIN171SX

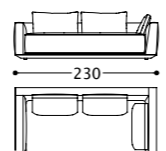

1CIN161SX
2CIN161SX

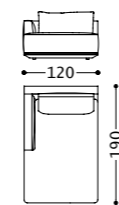

1CIN181SX
2CIN181SX

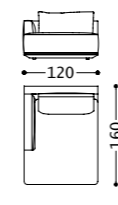

1CIN180SX
2CIN180SX

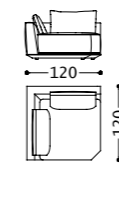

1CIN300
2CIN300

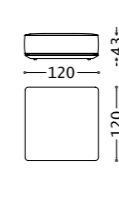

1CIN190
2CIN190

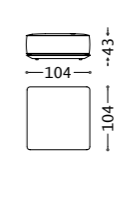

1CIN193
2CIN193

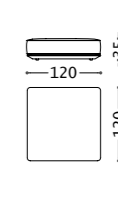

1CIN191
2CIN191

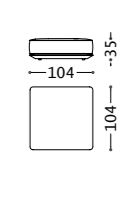

1CIN192
2CIN192

CINDY divano/sofa/canapé/sofa
composizioni/compositions/compositions/Kompositionen

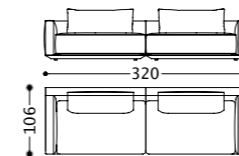

01CINC4
(1CIN100SX + 1CIN100DX)
02CINC4
(2CIN100SX + 2CIN100DX)

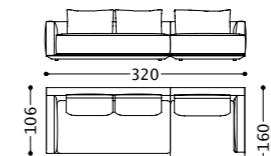

01CINC3
(1CIN110SX + 1CIN180DX)
02CINC3
(2CIN110SX + 2CIN180DX)

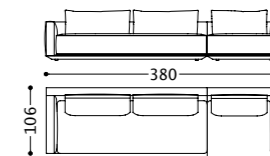

01CINC6
(1CIN130SX + 1CIN180DX)
02CINC6
(2CIN130SX + 2CIN180DX)

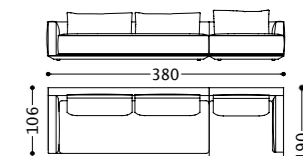

01CINC10
(1CIN130SX + 1CIN181DX)
02CINC10
(2CIN130SX + 2CIN181DX)

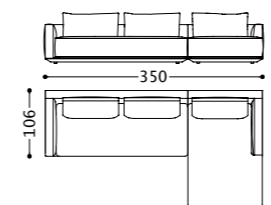

01CINC8
(1CIN120SX + 1CIN181DX)
02CINC8
(2CIN120SX + 2CIN181DX)

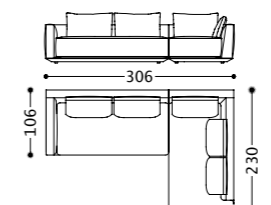

01CINC2
(1CIN110SX + 1CIN160DX)
02CINC2
(2CIN110SX + 2CIN160DX)

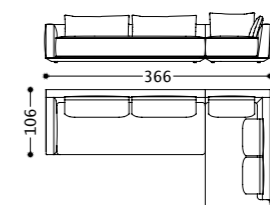

01CINC11
(1CIN130SX + 1CIN160DX)
02CINC11
(2CIN130SX + 2CIN160DX)

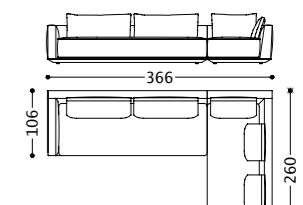

01CINC1
(1CIN130SX + 1CIN170DX)
02CINC1
(2CIN130SX + 2CIN170DX)

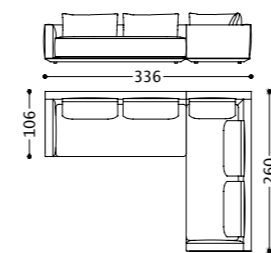

01CINC5
(1CIN120SX + 1CIN171DX)
02CINC5
(2CIN120SX + 2CIN171DX)

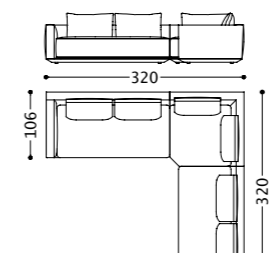

01CINC9
(1CIN110SX + 1CIN300 + 1CIN110DX)
02CINC9
(2CIN110SX + 2CIN300 + 2CIN110DX)

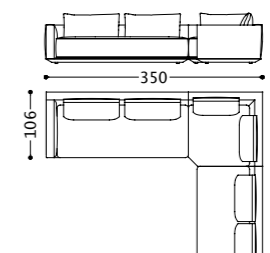

01CINC7
(1CIN120SX + 1CIN300 + 1CIN110DX)
02CINC7
(2CIN120SX + 2CIN300 + 2CIN110DX)



Struttura portante: Multistrato, massello di legno.
Imbottiture: Schienale in piuma d'oca. Seduta in piuma d'oca con inserto in poliuretano espanso (densità 30 Kg/mc). Bracciolo in piuma d'oca con inserto in poliuretano espanso a densità differenziata (40-25 Kg/mc).
Molleggio: Cinghie elastiche in polipropilene e gomma.
Piedino: In metallo (opzioni finitura: French Bronze o Gun Metal).

Main structure: Solid wood.
Upholstery: Backrest in goose feathers. Seat in goose feathers with internal padding in polyurethane foam (density 30 Kg/mc). Armrest in goose feathers with internal padding in polyurethane foam with different densities (40 - 25 Kg/mc).
Suspensions: Elastic belts in polypropylen and rubber.
Feet: In metal (finishing options: French Bronze or Gun Metal).

Structure: Multiplis et bois massif.
Rembourrage: Dossier en plume d'oie. Assise en plume d'oie avec insert en mousse de polyuréthane (densité 30 Kg/mc). Accoudoir en plume d'oie avec insert en mousse de polyuréthane avec plusieurs densités (40 - 25 Kg/mc).
Suspension: Sangles élastiques en polypropylène et mousse.
Feet: En metal (versions de finitions: French Bronze ou Gun Metal).

Struktur: Vielschichtiges Massivholz.
Polsterung: Rückenlehne aus Gänsedaunen. Sitz aus Gänsedaunen mit Einsatz aus Polyurethanschaum (Dichte 30 Kg/mc). Armlehne aus Gänsedaunen mit Einsatz aus Polyurethanschaum in unterschiedlichen Dichten (40 - 25 Kg/mc).
Federung: Elastische Gurte aus Gummi und Polypropylen.
Füße: Aus Metall (Auswahl: French Bronze oder Gun Metal).

Cod. Tessuto/fabric/tissu/Stoff: 01/1
 Cod. Pelle/leather/cuir/Leder: 02/2

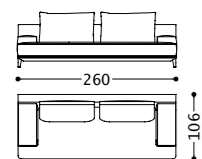

1RNN230
2RNN230

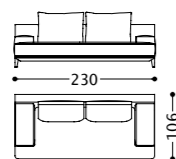

1RNN220
2RNN220

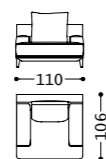

1RNN310
2RNN310

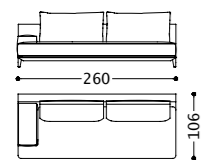

1RNN230SX
2RNN230SX

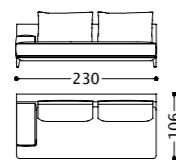

1RNN220SX
2RNN220SX

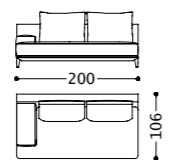

1RNN210SX
2RNN210SX

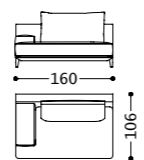

1RNN200SX
2RNN200SX

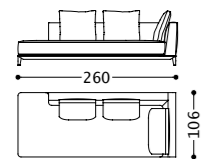

1RNN270SX
2RNN270SX

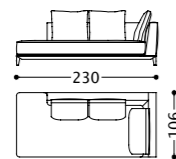

1RNN260SX
2RNN260SX

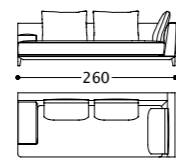

1RNN271SX
2RNN271SX

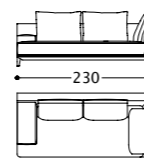

1RNN261SX
2RNN261SX

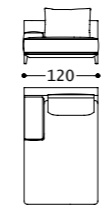

1RNN281SX
2RNN281SX

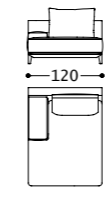

1RNN280SX
2RNN280SX

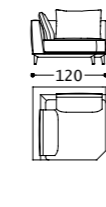

1RNN300
2RNN300

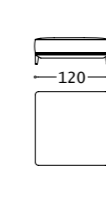

1RNN290
2RNN290

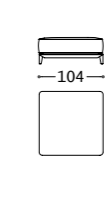

1RNN291
2RNN291

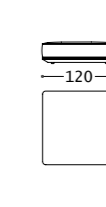

1RNN191
2RNN191

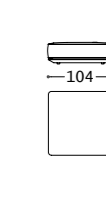

1RNN192
2RNN192

RONNY divano/sofa/canapé/sofa
 composizioni/compositions/compositions/Kompositionen

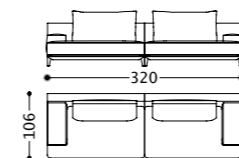

01RNNC4
(1RNN200SX + 1RNN200DX)
02RNNC4
(2RNN200SX + 2RNN200DX)

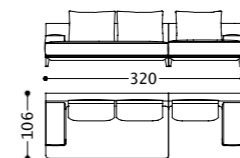

01RNNC3
(1RNN210SX + 1RNN280DX)
02RNNC3
(2RNN210SX + 2RNN280DX)

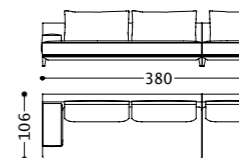

01RNNC6
(1RNN230SX + 1RNN280DX)
02RNNC6
(2RNN230SX + 2RNN280DX)

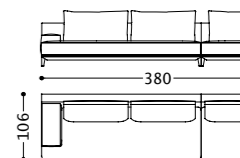

01RNNC10
(1RNN230SX + 1RNN281DX)
02RNNC10
(2RNN230SX + 2RNN281DX)

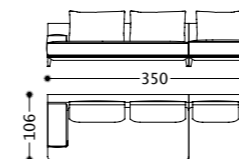

01RNNC8
(1RNN220SX + 1RNN281DX)
02RNNC8
(2RNN220SX + 2RNN281DX)

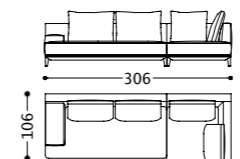

01RNNC2
(1RNN210SX + 1RNN260DX)
02RNNC2
(2RNN210SX + 2RNN260DX)

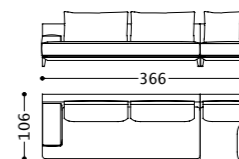

01RNNC11
(1RNN230SX + 1RNN260DX)
02RNNC11
(2RNN230SX + 2RNN260DX)

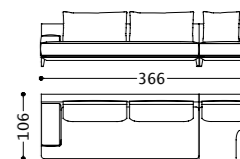

01RNNC1
(1RNN230SX + 1RNN270DX)
02RNNC1
(2RNN230SX + 2RNN270DX)

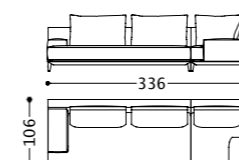

01RNNC5
(1RNN220SX + 1RNN271DX)
02RNNC5
(2RNN220SX + 2RNN271DX)

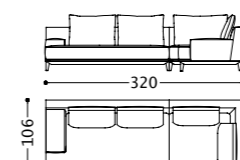

01RNNC9
(1RNN210SX + 1RNN300 + 1RNN210DX)
02RNNC9
(2RNN210SX + 2RNN300 + 2RNN210DX)

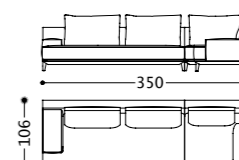

01RNNC7
(1RNN220SX + 1RNN300 + 1RNN210DX)
02RNNC7
(2RNN220SX + 2RNN300 + 2RNN210DX)

MORRISON divano/sofa/canapé/sofa
 elementi/elements/éléments/elemente



Struttura portante: Multistrato, massello di legno.
Imbottiture: Schienale in piuma d'oca. Seduta in piuma d'oca con inserto in poliuretano espanso a densità differenziata (30-25 Kg/mc). Bracciolo in piuma d'oca con inserto in poliuretano espanso a densità differenziata (40-25 Kg/mc).
Molleggio: Cinghie elastiche in polipropilene e gomma.
Piedino: In ABS.

Main structure: Solid wood.
Upholstery: Backrest in goose feathers. Seat in goose feathers with internal padding in polyurethane foam with different densities (30-25 Kg/mc). Armrest in goose feathers with internal padding in polyurethane foam with different densities (40 - 25 Kg/mc).
Suspensions: Elastic belts in polypropylen and rubber.
Feet: In ABS.

Structure: Multiplis et bois massif.
Rembourrage: Dossier en plume d'oie. Assise en plume d'oie avec insert en mousse de polyuréthane avec plusieurs densités (30-25 Kg/mc). Accoudoir en plume d'oie avec insert en mousse de polyuréthane avec plusieurs densités (40 - 25 Kg/mc).
Suspension: Sangles élastiques en polypropylène et mousse.
Feet: En ABS.

Struktur: Vielschichtiges Massivholz.
Polsterung: Rückenlehne aus Gänsedaunen. Sitz aus Gänsedaunen mit Einsatz aus Polyurethanschaum in unterschiedlichen Dichten (30-25 Kg/mc). Armlehne aus Gänsedaunen mit Einsatz aus Polyurethanschaum in unterschiedlichen Dichten (40 - 25 Kg/mc).
Federung: Elastische Gurte aus Gummi und Polypropylen.
Füße: ABS.

Cod. Tessuto/fabric/tissu/Stoff: 01/1
 Cod. Pelle/leather/cuir/Leder: 02/2

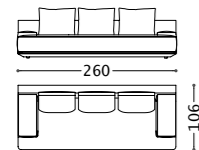
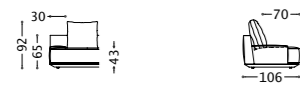

1MOR130
2MOR130

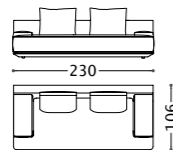

1MOR120
2MOR120

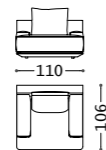

1MOR310
2MOR310

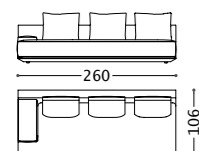

1MOR130SX
2MOR130SX

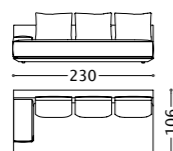

1MOR120SX
2MOR120SX

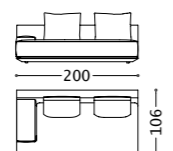

1MOR110SX
2MOR110SX

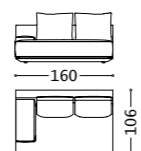

1MOR100SX
2MOR100SX

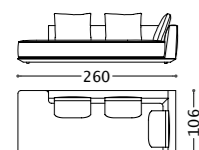

1MOR170SX
2MOR170SX

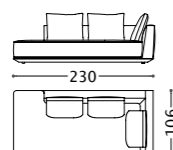

1MOR160SX
2MOR160SX

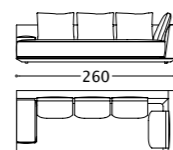

1MOR171SX
2MOR171SX

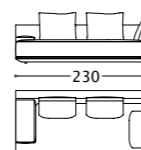

1MOR161SX
2MOR161SX

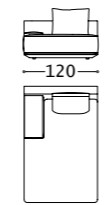

1MOR181SX
2MOR181SX

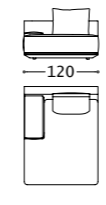

1MOR180SX
2MOR180SX

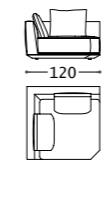

1MOR300
2MOR300

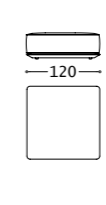

1MOR190
2MOR190

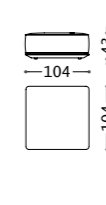

1MOR193
2MOR193

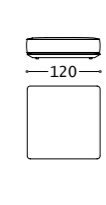

1MOR191
2MOR191

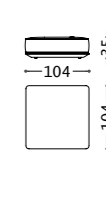

1MOR192
2MOR192

MORRISON divano/sofa/canapé/sofa
 composizioni/compositions/compositions/Kompositionen

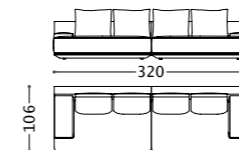

01MORC4
(1MOR100SX + 1MOR100DX)
02MORC4
(2MOR100SX + 2MOR100DX)

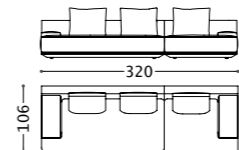

01MORC3
(1MOR110SX + 1MOR180DX)
02MORC3
(2MOR110SX + 2MOR180DX)

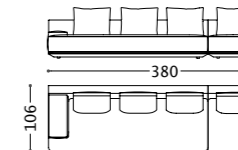

01MORC6
(1MOR130SX + 1MOR180DX)
02MORC6
(2MOR130SX + 2MOR180DX)

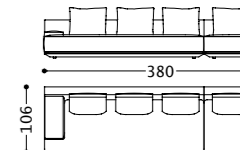

01MORC10
(1MOR130SX + 1MOR181DX)
02MORC10
(2MOR130SX + 2MOR181DX)

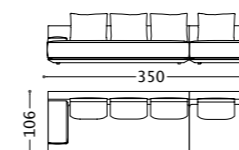

01MORC8
(1MOR120SX + 1MOR181DX)
02MORC8
(2MOR120SX + 2MOR181DX)

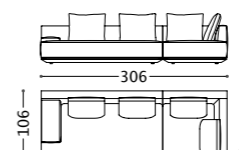

01MORC2
(1MOR110SX + 1MOR160DX)
02MORC2
(2MOR110SX + 2MOR160DX)

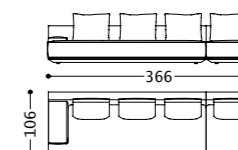

01MORC11
(1MOR130SX + 1MOR160DX)
02MORC11
(2MOR130SX + 2MOR160DX)

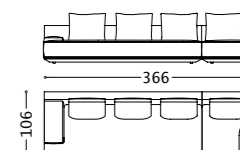

01MORC1
(1MOR130SX + 1MOR170DX)
02MORC1
(2MOR130SX + 2MOR170DX)

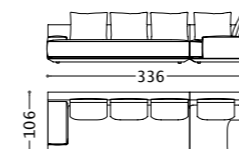

01MORC5
(1MOR120SX + 1MOR171DX)
02MORC5
(2MOR120SX + 2MOR171DX)

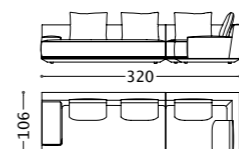

01MORC9
(1MOR110SX + 1MOR300 + 1MOR110DX)
02MORC9
(2MOR110SX + 2MOR300 + 2MOR110DX)

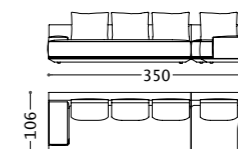

01MORC7
(1MOR120SX + 1MOR300 + 1MOR110DX)
02MORC7
(2MOR120SX + 2MOR300 + 2MOR110DX)

BRUCE divano/sofa/canapé/sofa
elementi/elements/éléments/elemente



Struttura portante: Multistrato, massello di legno.
Imbottiture: Schienale in piuma d'oca. Seduta in piuma d'oca con inserto in poliuretano espanso a densità differenziata (30-25 Kg/mc). Bracciolo in piuma d'oca con inserto in poliuretano espanso a densità differenziata (40-25 Kg/mc).
Molleggio: Cinghie elastiche in polipropilene e gomma.
Piedino: In ABS.

Main structure: Solid wood.
Upholstery: Backrest in goose feathers. Seat in goose feathers with internal padding in polyurethane foam with different densities (30-25 Kg/mc). Armrest in goose feathers with internal padding in polyurethane foam with different densities (40 - 25 Kg/mc).
Suspensions: Elastic belts in polypropylen and rubber.
Feet: In ABS.

Structure: Multiplis et bois massif.
Rembourrage: Dossier en plume d'oie. Assise en plume d'oie avec insert en mousse de polyuréthane avec plusieurs densités (30-25 Kg/mc). Accoudoir en plume d'oie avec insert en mousse de polyuréthane avec plusieurs densités (40 - 25 Kg/mc).
Suspension: Sangles élastiques en polypropylène et mousse.
Feet: En ABS.

Struktur: Vielschichtiges Massivholz.
Polsterung: Rückenlehne aus Gänsedaunen. Sitz aus Gänsedaunen mit Einsatz aus Polyurethanschaum in unterschiedlichen Dichten (30-25 Kg/mc). Armlehne aus Gänsedaunen mit Einsatz aus Polyurethanschaum in unterschiedlichen Dichten (40 - 25 Kg/mc).
Federung: Elastische Gurte aus Gummi und Polypropylen.
Füße: ABS.

Cod. Tessuto/fabric/tissu/Stoff: 01/1
Cod. Pelle/leather/cuir/Leder: 02/2

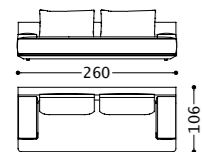

1BRU130
2BRU130

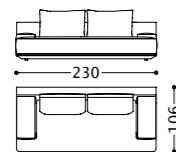

1BRU120
2BRU120

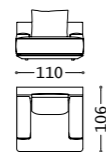

1BRU310
2BRU310

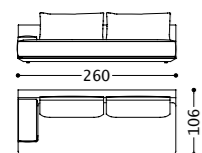

1BRU130SX
2BRU130SX

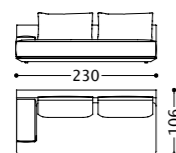

1BRU120SX
2BRU120SX

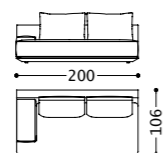

1BRU110SX
2BRU110SX

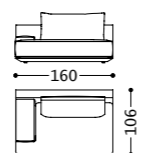

1BRU100SX
2BRU100SX

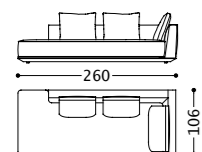

1BRU170SX
2BRU170SX

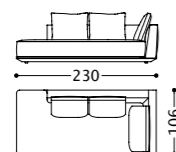

1BRU160SX
2BRU160SX

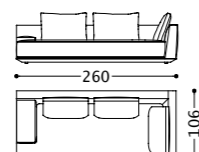

1BRU171SX
2BRU171SX

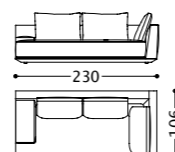

1BRU161SX
2BRU161SX

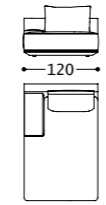

1BRU181SX
2BRU181SX

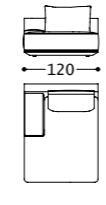

1BRU180SX
2BRU180SX

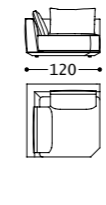

1BRU300
2BRU300

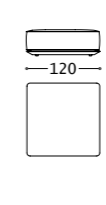

1BRU190
2BRU190

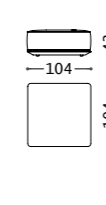

1BRU193
2BRU193

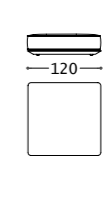

1BRU191
2BRU191

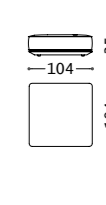

1BRU192
2BRU192

BRUCE divano/sofa/canapé/sofa
composizioni/compositions/compositions/Kompositionen

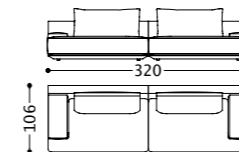

01BRUC4
(1BRU100SX + 1BRU100DX)
02BRUC4
(2BRU100SX + 2BRU100DX)

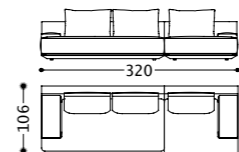

01BRUC3
(1BRU110SX + 1BRU180DX)
02BRUC3
(2BRU110SX + 2BRU180DX)

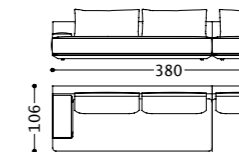

01BRUC6
(1BRU130SX + 1BRU180DX)
02BRUC6
(2BRU130SX + 2BRU180DX)

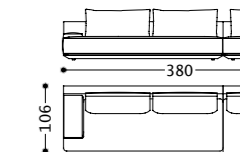

01BRUC10
(1BRU130SX + 1BRU181DX)
02BRUC10
(2BRU130SX + 2BRU181DX)

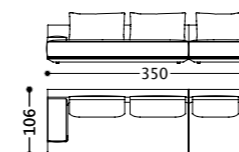

01BRUC8
(1BRU120SX + 1BRU181DX)
02BRUC8
(2BRU120SX + 2BRU181DX)

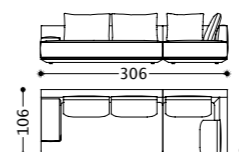

01BRUC2
(1BRU110SX + 1BRU160DX)
02BRUC2
(2BRU110SX + 2BRU160DX)

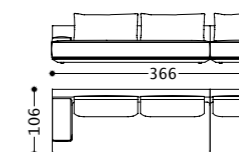

01BRUC11
(1BRU130SX + 1BRU160DX)
02BRUC11
(2BRU130SX + 2BRU160DX)

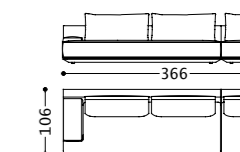

01BRUC1
(1BRU130SX + 1BRU170DX)
02BRUC1
(2BRU130SX + 2BRU170DX)

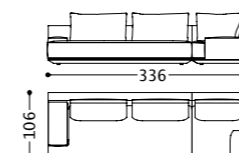

01BRUC5
(1BRU120SX + 1BRU171DX)
02BRUC5
(2BRU120SX + 2BRU171DX)

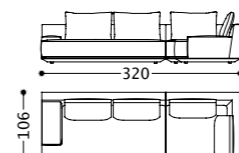

01BRUC9
(1BRU110SX + 1BRU300 + 1BRU110DX)
02BRUC9
(2BRU110SX + 2BRU300 + 2BRU110DX)

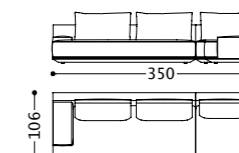

01BRUC7
(1BRU120SX + 1BRU300 + 1BRU110DX)
02BRUC7
(2BRU120SX + 2BRU300 + 2BRU110DX)

YOKO 1 divano/sofa/canapé/sofa

elementi/elements/éléments/elemente



Struttura portante: Multistrato, massello di legno. Il cuscino schienale rettangolare è in multistrato con rinforzo in metallo.
Imbottiture: Cuscino schienale rettangolare in piuma d'oca con inserto in poliuretano espanso a densità differenziata (40-30 Kg/mc) rivestito in tela cotone/poliestere. Cuscino schienale in piuma d'oca rivestito in tela cotone/poliestere. Cuscino bracciolo in piuma d'oca con inserto in poliuretano espanso a densità 30 kg/mc rivestito in tela cotone/poliestere. Seduta in piuma d'oca con inserto in poliuretano espanso a densità differenziata (40-150 Kg/mc) rivestito in tela cotone/poliestere.
Molle: Cinghie elastiche in polipropilene e gomma.
Piedino: In ABS.

Main structure: Solid wood. Rectangular back cushion in solid wood with metal support.
Upholstery: Rectangular back cushion in goose feathers with internal padding in polyurethane foam with different densities (40-30 Kg/mc) covered with cotton/polyester fabric. Back cushion in goose feathers covered with cotton/polyester fabric. Arm pillow in goose feathers with internal padding in polyurethane foam (density 30 kg/mc) covered with cotton/polyester fabric. Seat in goose feathers with internal padding in polyurethane foam with different densities (40-150 Kg/mc) covered with cotton/polyester fabric.
Suspensions: Elastic belts in polypropylen and rubber.
Feet: In ABS.

Structure: Multiplis et bois massif. Coussin de dossier rectangulaire en multiplis et renforcement métallique.
Rembourrage: Coussin de dossier rectangulaire en plume d'oie avec insert en mousse de polyuréthane en plusieurs densités (40-30 Kg/mc) sous housse de coton/polyester. Coussin de dossier en plume d'oie sous housse de coton/polyester. Coussin accoudoir en plume d'oie avec insert en mousse de polyuréthane (densité 30 Kg/mc) sous housse de coton/polyester. Assise en plume d'oie avec insert en mousse de polyuréthane en plusieurs densités (40-150 kg/mc) sous housse de coton/polyester.
Suspension: Sangles élastiques en polypropylène et mousse.
Feet: En ABS.

Struktur: Vielschichtiges Massivholz. Rechteckiger Rückenissen aus vielschichtiges Massivholz mit Metallverstärkung.
Polsterung: Rechteckiger Rückenissen aus Gänsedaunen mit Einsatz aus Polyurethanschaum in unterschiedlichen Dichten (40-30 Kg/mc) mit Baumwolle /Polyester Bezug abgedeckt. Rückenissen aus Gänsedaunen mit Baumwolle /Polyester Bezug abgedeckt. Arm-kissen aus Gänsedaunen mit Einsatz aus Polyurethanschaum (Dichte 30 Kg/mc) mit Baumwolle /Polyester Bezug abgedeckt. Sitz aus Gänsedaunen mit Einsatz aus Polyurethanschaum in unterschiedlichen Dichten (40-150 kg/mc) mit Baumwolle /Polyester Bezug abgedeckt.
Federung: Elastische Gurte aus Gummi und Polypropylen.
Füße: ABS.

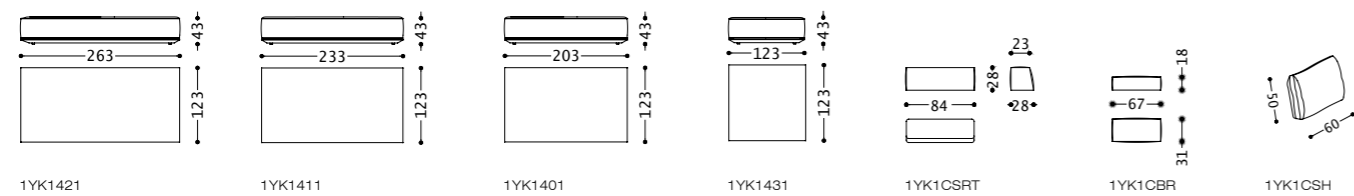

YOKO 1 divano/sofa/canapé/sofa

composizioni/compositions/compositions/Kompositionen

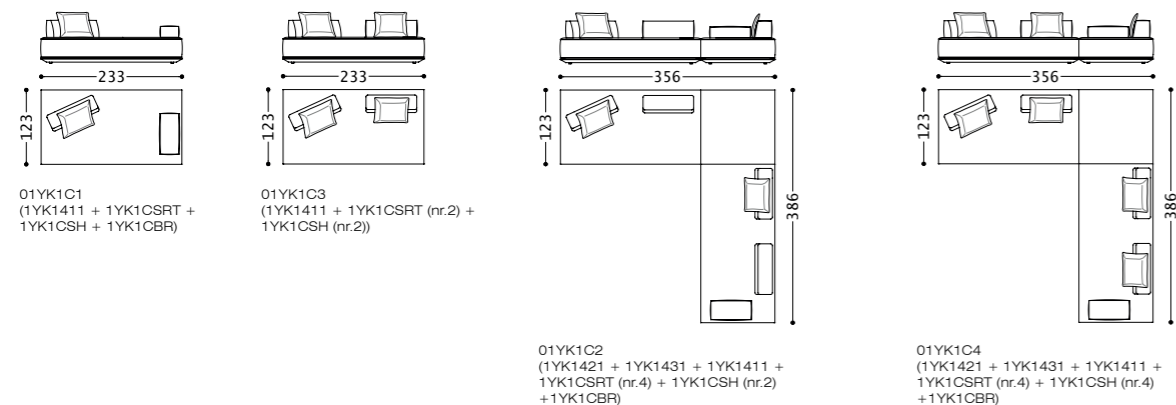

YOKO 2 divano/sofa/canapé/sofa

elementi/elements/éléments/elemente



Struttura portante: Multistrato, massello di legno. Il cuscino schienale rettangolare è in multistrato con rinforzo in metallo.
Imbottiture: Cuscino schienale rettangolare in piuma d'oca con inserto in poliuretano espanso a densità differenziata (40-30 Kg/mc) rivestito in tela cotone/poliestere. Cuscino schienale in piuma d'oca rivestito in tela cotone/poliestere. Cuscino bracciolo in piuma d'oca con inserto in poliuretano espanso a densità 30 kg/mc rivestito in tela cotone/poliestere. Seduta in piuma d'oca con inserto in poliuretano espanso a densità differenziata (40-150 Kg/mc) rivestito in tela cotone/poliestere.
Molle: Cinghie elastiche in polipropilene e gomma.
Piedino: In metallo (finiture French Bronze o Gun Metal).

Main structure: Solid wood. Rectangular back cushion in solid wood with metal support.
Upholstery: Rectangular back cushion in goose feathers with internal padding in polyurethane foam with different densities (40-30 Kg/mc) covered with cotton/polyester fabric. Back cushion in goose feathers covered with cotton/polyester fabric. Arm pillow in goose feathers with internal padding in polyurethane foam (density 30 kg/mc) covered with cotton/polyester fabric. Seat in goose feathers with internal padding in polyurethane foam with different densities (40-150 Kg/mc) covered with cotton/polyester fabric.
Suspensions: Elastic belts in polypropylen and rubber.
Feet: Metal (finishing options: French Bronze or Gun Metal).

Structure: Multiplis et bois massif. Coussin de dossier rectangulaire en multiplis et renforcement métallique.
Rembourrage: Coussin de dossier rectangulaire en plume d'oie avec insert en mousse de polyuréthane en plusieurs densités (40-30 Kg/mc) sous housse de coton/polyester. Coussin de dossier en plume d'oie sous housse de coton/polyester. Coussin accoudoir en plume d'oie avec insert en mousse de polyuréthane (densité 30 Kg/mc) sous housse de coton/polyester. Assise en plume d'oie avec insert en mousse de polyuréthane en plusieurs densités (40-150 kg/mc) sous housse de coton/polyester.
Suspension: Sangles élastiques en polypropylène et mousse.
Feet: En métal (versions de finitions: French Bronze ou Gun Metal).

Struktur: Vielschichtiges Massivholz. Rechteckiger Rückenissen aus vielschichtiges Massivholz mit Metallverstärkung.
Polsterung: Rechteckiger Rückenissen aus Gänsedaunen mit Einsatz aus Polyurethanschaum in unterschiedlichen Dichten (40-30 Kg/mc) mit Baumwolle /Polyester Bezug abgedeckt. Rückenissen aus Gänsedaunen mit Baumwolle /Polyester Bezug abgedeckt. Arm-kissen aus Gänsedaunen mit Einsatz aus Polyurethanschaum (Dichte 30 Kg/mc) mit Baumwolle /Polyester Bezug abgedeckt. Sitz aus Gänsedaunen mit Einsatz aus Polyurethanschaum in unterschiedlichen Dichten (40-150 kg/mc) mit Baumwolle /Polyester Bezug abgedeckt.
Federung: Elastische Gurte aus Gummi und Polypropylen.
Füße: Aus Metall (Auswahl: French Bronze oder Gun Metal).

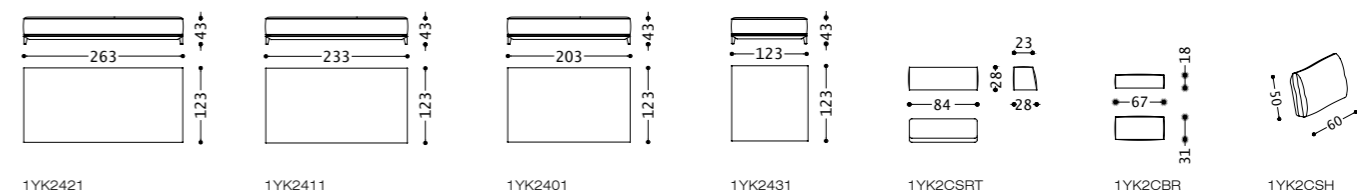

YOKO 2 divano/sofa/canapé/sofa

composizioni/compositions/compositions/Kompositionen

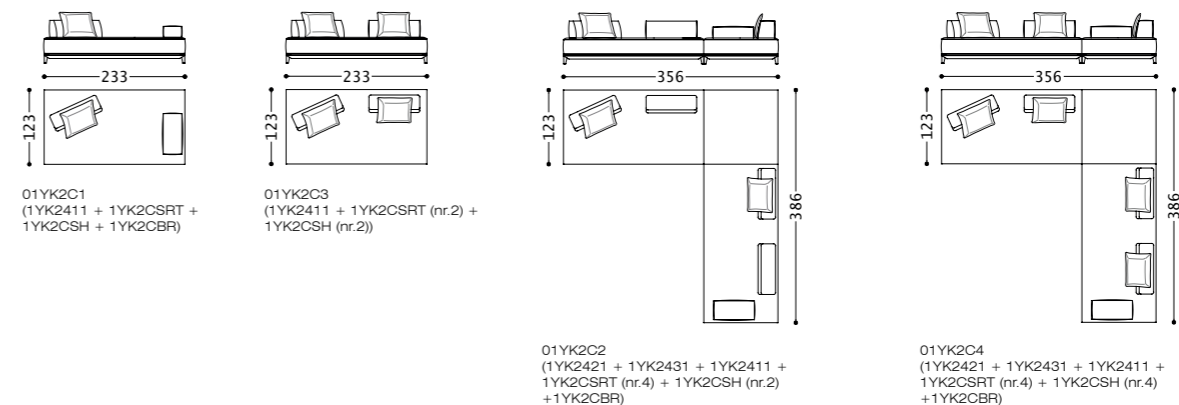

GOSSIP poltrona/armchair/fauteuil/Sessel

elementi/elements/éléments/Elemente



Struttura portante: multistrato, massello di legno.
Imbottiture: Schienale e seduta in poliuretano espanso (densità 40 Kg/mc).
Molleggio: cinghie elastiche in polipropilene e gomma.
Piedino: in ABS.

Main structure: solid wood.
Upholstery: Backrest and seat in polyurethane foam (density 40 Kg/mc).
Suspensions: elastic belts in polypropylen and rubber.
Feet: in ABS.

Structure: Multiplis et bois massif.
Rembourrage: Dossier et assise en mousse de polyuréthane (densité 40 kg/mc).
Suspension: sangles élastiques en polypropylène et mousse.
Feet: en ABS.

Struktur: vielschichtiges Massivholz.
Polsterung: Rückenlehne und Sitz aus Polyurethanschaum (Dichte 40 Kg/mc).
Federung: elastische Gurte aus Gummi und Polypropylen.
Füße: ABS.

Cod. Tessuto/fabric/tissu/Stoff: 1
Cod. Pelle/leather/cuir/Leder: 2

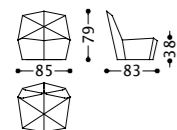

1GSPP
2GSPP

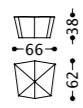

1GSPPPUFF
2GSPPPUFF

FENDER poltrona/armchair/fauteuil/Sessel

elementi/elements/éléments/Elemente



Struttura portante: multistrato, massello di legno.
Imbottiture: poliuretano espanso a densità differenziata (65-75 Kg/mc).
Molleggio: cinghie elastiche in polipropilene e gomma.
Versione fissa: piede in metallo (finiture French Bronze o Gun Metal).
Versione girevole: basamento girevole in metallo (finiture French Bronze o Gun Metal).

Main structure: solid wood.
Upholstery: in polyurethane foam with different densities (65-75 Kg/mc).
Suspensions: elastic belts in polypropylen and rubber.
Fix version: metal feet (finishing options: French Bronze or Gun Metal).
Swivel version: metal base (finishing options: French Bronze or Gun Metal).

Structure: multiplis et bois massif.
Rembourrage: en mousse de polyuréthane avec plusieurs densités (65-75 Kg/mc).
Suspension: sangles élastiques en polypropylène et mousse.
Version fixe: pied en métal (versions de finitions: French Bronze ou Gun Metal).
Version tournante: piétement pivotant en métal (versions de finitions: French Bronze ou Gun Metal).

Struktur: vielschichtiges Massivholz.
Polsterung: aus Polyurethanschaum in unterschiedlichen Dichten (65-75 Kg/mc).
Federung: elastische Gurte aus Gummi und Polypropylen.
Fest-Version: Fuß aus Metall (Auswahl: French Bronze oder Gun Metal).
Dreh-Version: Drehbasis aus Metall (Auswahl: French Bronze oder Gun Metal).

Cod. tessuto/fabric/tissu/Stoff: 1
Cod. pelle/leather/cuir/Leder: 2

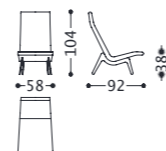

1FENPA
2FENPA

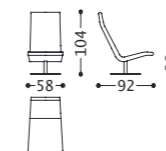

1FENPAG
2FENPAG

JAMMIN • JAMMIN LARGE poltrona/armchair/fauteuil/Sessel

elementi/elements/éléments/Elemente



Struttura portante: multistrato, massello di legno.

Imbottiture: Schienale in poliuretano espanso (densità 21 Kg/mc). Seduta in piuma d'oca con inserto in poliuretano espanso (densità 40 Kg/mc).

Versione fissa: piede in metallo (finiture French Bronze o Gun Metal).

Versione girevole: basamento girevole in metallo (finiture French Bronze o Gun Metal).

Main structure: solid wood.

Upholstery: Backrest in polyurethane foam (density 21 Kg/mc). Seat in goose feathers with internal padding in polyurethane foam (density 40 Kg/mc).

Fix version: metal feet (finishing options: French Bronze or Gun Metal).

Swivel version: metal base (finishing options: French Bronze or Gun Metal).

Structure: Multiplis et bois massif.

Rembourrage: Dossier en mousse de polyuréthane (densité 21 kg/mc). Assise en plume d'oie avec insert en mousse de polyuréthane (densité 40 kg/mc).

Version fixe: pied en métal (versions de finitions: French Bronze ou Gun Metal).

Version tournante: piétement pivotant en métal (versions de finitions: French Bronze ou Gun Metal).

Struktur: vielschichtiges Massivholz.

Polsterung: Rückenlehne aus Polyurethanschaum (Dichte 21 Kg/mc). Sitz aus Gänsedaunen mit Einsatz aus Polyurethanschaum (Dichte 40 Kg/mc).

Fest-Version: Fuß aus Metall (Auswahl: French Bronze oder Gun Metal).

Dreh-Version: Drehbasis aus Metall (Auswahl: French Bronze oder Gun Metal).

Cod. Tessuto/fabric/tissu/Stoff: 1

Cod. Pelle/leather/cuir/Leder: 2

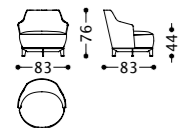

1JAMP
2JAMP

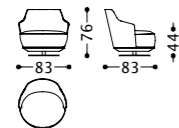

1JAMPG
2JAMPG

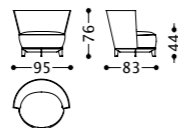

1JAMPL
2JAMPL

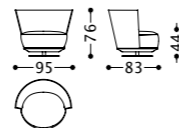

1JAMPLG
2JAMPLG

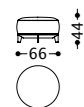

1JAMPOUFF
2JAMPOUFF

JAGGER tavolino/small table/table/Couchtisch

elementi/elements/éléments/Elemente



Struttura: metallica a 5 gambe.

Finitura struttura: laccato.

Top: MDF.

Finitura top: laccato.

Structure: in metal with 5 legs.

Structure finishing: lacquered.

Top: MDF.

Top finishing: lacquered.

Structure: en métal avec 5 jambes.

Finition de la structure: laqué.

Plateau: MDF.

Finition du plateau: laqué.

Struktur: aus Metall mit 5 Beine.

Strukturbearbeitung: lackiert.

Top: MDF.

Topbearbeitung: lackiert.



1JAGTH



1JAGTL



1JAGTM

BABAR tavolino/small table/table/Couchtisch

elementi/elements/éléments/Elemente



Struttura portante: legno multistrato e MDF.

Finitura struttura: laccato.

Structure: solid wood and MDF.

Structure finishing: lacquered.

Structure: multiplis et MDF.

Finition de la structure: laqué.

Struktur: vielschichtiges Massivholz und MDF.

Strukturbearbeitung: lackiert.



1BBRTROT

PHIL tavolino/small table/table/Couchtisch
 elementi/elements/éléments/Elemente



Struttura: metallica.
Finitura struttura: French Bronze o Gun Metal.
Top: in marmo o MDF (laccato).

Structure: in metal.
Structure finishing: French Bronze or Gun Metal.
Top: marble or MDF (lacquered).

Structure: en métal.
Finition de la structure: French Bronze ou Gun Metal.
Plateau: marbre ou MDF (laqué).

Struktur: aus Metall.
Strukturbearbeitung: French Bronze oder Gun Metal.
Top: Marmor oder MDF (lackiert).



1PHISER
 1PHISERL

HUGO tavolino/small table/table/Couchtisch
 elementi/elements/éléments/Elemente



Struttura portante: MDF.
Finitura struttura: laccato.

Structure: MDF.
Structure finishing: lacquered.

Structure: MDF.
Finition de la structure: laqué.

Struktur: MDF.
Strukturbearbeitung: lackiert.

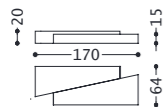

0HUGC1

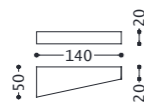

1HUGTH

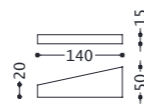

1HUGTL

FRISCO tavolino/small table/table/Couchtisch
 elementi/elements/éléments/Elemente



Struttura: metallica.
Finitura struttura: French Bronze o Gun Metal.
Top alto (1): marmo o MDF (laccato).
Top basso (2): MDF (laccato).

Structure: in metal.
Structure finishing: French Bronze or Gun Metal.
Top high (1): marble or MDF (lacquered).
Top low (2): MDF (lacquered).

Structure: en métal.
Finition de la structure: French Bronze ou Gun Metal.
Plateau haut (1): marbre ou MDF (laqué).
Plateau bas (2): MDF (laqué).

Struktur: aus Metall.
Strukturbearbeitung: French Bronze oder Gun Metal.
Hoher Top (1): Marmor oder MDF (lackiert).
Niedriger Top (2): MDF (lackiert).



1FRITROT
 1FRITROT L

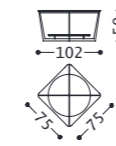

1FRITAVQA
 1FRITAVQAL

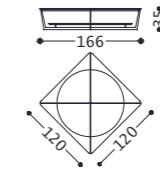

1FRITAVQB
 1FRITAVQBL

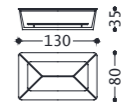

1FRITAVR
 1FRITAVRL





Art Direction
Product Development
Set Coordination
Graphic Project
Castello Lagravinese Studio



Photography
Davide Cerati
Styling
Sissi Valassina
Graphic Assistant
Bplus marketing
Print
Grafiche Antiga

alberta

via Toniolo 41
31028 Vazzola (TV) - ITALY
T +39 0438 440440
F +39 0438 441555
www.alberta.it